



# SHORELOK-48

Safe and Efficient Scaffolding  
Solutions





**Disclaimer:**

While every effort has been made to ensure the accuracy of the information in this catalogue, we cannot accept responsibility for any errors which may occur as a result of reliance on the contents of this catalogue and are not liable for any loss of any nature that may be incurred as a result of such reliance. Details of any of the products may change without prior notice.

The customer must ensure that 'good practice' is adopted on site by competent persons and that the products shown in this catalogue are erected, used and stripped in accordance with the relevant Codes of Practice, international standards and the local authorities regulations. This catalogue does not contain any design detail but lists and depicts the items available under this product range. The responsibility for design is the responsibility of the customer. Please, contact Scaffco's engineer for any technical inquiries.

تنويه:

في حين تم بذل كل جهد ممكن لضمان دقة المعلومات الواردة في هذا الدليل، لا يمكن أن تقبل شركة سكايفكو المسؤولية عن أي أخطاء قد تحدث نتيجة الاعتماد على أي من محتويات هذا الدليل، والشركة غير مسؤولة عن أي خسارة من أي نوع قد يتم تكبدها نتيجة لأعتماد محتويات هذا الدليل. تحتفظ الشركة بحق تغيير أي من المنتجات أو التفاصيل دون إشعار مسبق.

يجب على العملاء التأكد من أن يتم تبني الممارسات الصحيحة في الموقع من ناحية استخدام المعدات المذكورة في هذا الدليل. كذلك يجب على العملاء التأكد من كفاءة وحرفية الأشخاص القائمين على تركيب واستعمال وتفكيك عناصر الأنظمة وأن تكون هذه العمليات متطابقة مع المتطلبات والمعايير المذكورة في المواصفات الدولية ذات العلاقة ولوائح وتعليمات السلطات المحلية. هذا الدليل لا يحتوي على أية تفاصيل تخص التصميم ولكن يصف مكونات الأنظمة بشكل تصويري ويعطي فكرة عن عناصر الأنظمة المتاحة في إطار هذه المجموعة من المنتجات. الرجاء الاتصال بمهندس شركة سكايفكو للحصول على أي استفسارات فنية تخص المنتجات المذكورة في هذا الدليل.



# SCAFFCO

## Formwork & Scaffolding

SCAFFCO has a proven history of over 40 years in designing, manufacturing, and supplying scaffolding and formwork solutions for the Construction, Infrastructure, O&G and Industrial sectors.

Established in 1980, as an agent of leading brands of scaffolding and formwork products, SCAFFCO has rapidly grown to become a recognized manufacturer and solution provider for scaffolding and formwork systems with an established local and export network covering the GCC, Africa, and Europe.

Our unique value proposition model is driven by superior safety & quality standards, versatile systems, operational excellence and value engineering. All dedicated to address customer specific needs.

Today our manufacturing operations are based in two facilities located JAFZA – Dubai & Mussafah ICAD1 – Abu Dhabi and extend over an area of more than 50,000 Square meters. Our manufacturing facilities are equipped with automated robotic production units and embrace a robust and comprehensive quality system and process controls. The company has a production capacity that exceeds 50,000 tons of products annually.

In addition to our leading manufacturing capabilities, we have established a proven track record of expertise offering solutions from design, manufacturing, pre-assembly up to installation, training, supervision and inspection services on site. Our executed projects reference list includes a large selection of prestigious and landmark projects.

## Mission Statement

At SCAFFCO, we are dedicated to creating value for our customers by providing optimized and efficient Scaffolding and Formwork solutions in accordance with the highest international safety and quality standards.

## Vision Statement

Our vision is to set global benchmarks in scaffolding and formwork, pioneering innovation, safety, and quality in construction. We aim to redefine industry standards, pushing boundaries with relentless commitment to excellence.

# Safe and Efficient Scaffolding Solutions.

Shorelok is an innovative modular scaffold system that not only significantly reduces labour costs but also meets the highest safety standards, offers exceptional ease of handling, and minimizes maintenance requirements. It is a versatile system, accompanied by a comprehensive range of accessories to suit various applications.

The Shorelok System Scaffold is a revolutionary, tool-free assembly system. Its components seamlessly slot into the unique leg rosette, securely locking in place with the simple act of hammering a captive wedge. Being entirely modular and pre-measured, it facilitates rapid assembly, ultimately saving time and labour costs. The robust steel rosette welded to the verticals at 0.5m intervals is the linchpin behind the remarkable adaptability of the Shorelok Scaffold system.

Welded to vertical standards, these rosettes eliminate the need for on-site measurements when connecting ledgers and braces. This system can achieve up to eight connections in a single plane, enabling it to conform to diverse shapes securely and rigidly. This feature makes the Shorelok system perfect for standard scaffolding requirements and adaptable to structures with varying geometries.

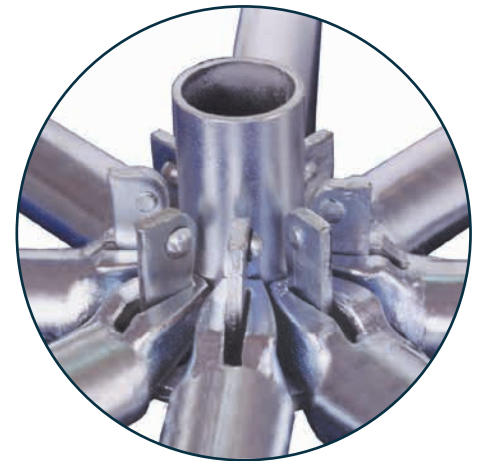

The versatility of the Shorelok system has led to its use in:

- Construction & renovation



- Infrastructure



- Mining



- Chemical plants



- Oil & gas



- Off-shore



- Power plants



- Maritime industry



The advantages of the Shorelok extend beyond efficient assembly and disassembly. This system is maintenance-free and offers storage convenience. Its components are constructed from high-tensile steel, hot-dipped galvanized to eliminate greasing of bases and bolts, prevent rust and corrosion, and eliminate the need to replace loose fittings. This translates to significant labour and maintenance cost savings.

The versatility of the Shorelok system has led to its widespread adoption in a variety of applications, making it the ideal choice for those seeking cost-effective, adaptable, and safe scaffold solutions.



The modular Shorelok system is characterised by the standardised, fast and simple assembly. The actions below are repeated:



1- Place the ledger or the diagonal in the desired position;

2- Position the metal wedge in the appropriate opening

3- Drive the wedge in with a hammer

This creates a connection that can bear very heavy loads. In this way, as many as four ledgers and four diagonals can be attached to one ring!

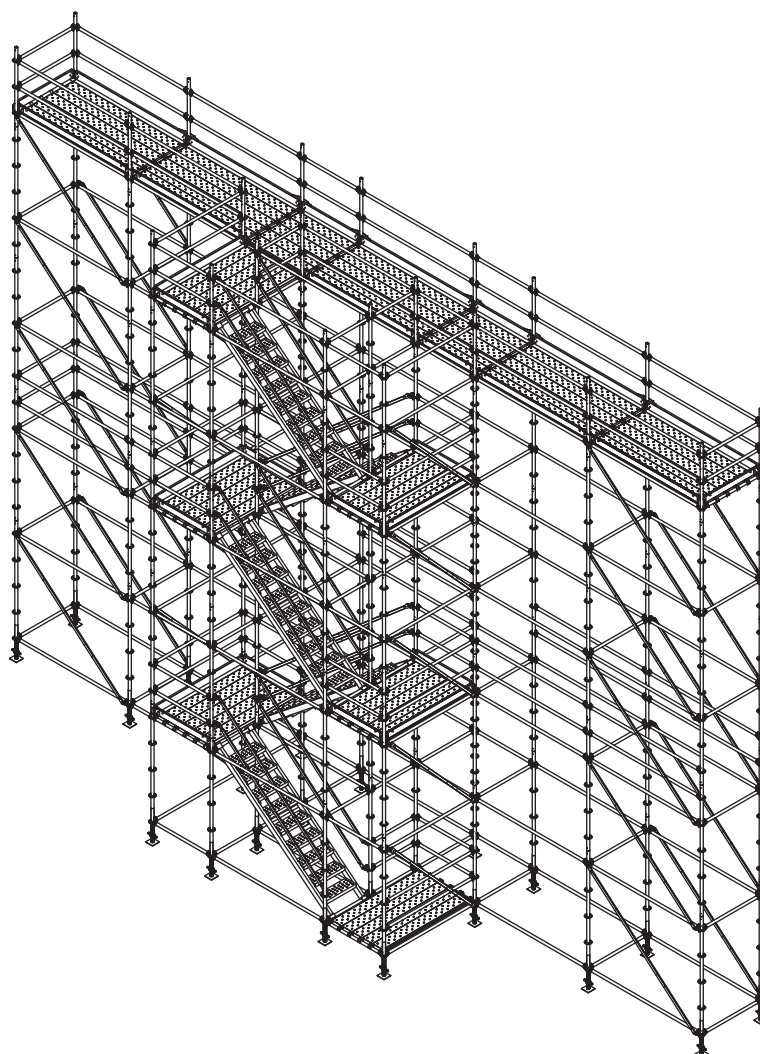
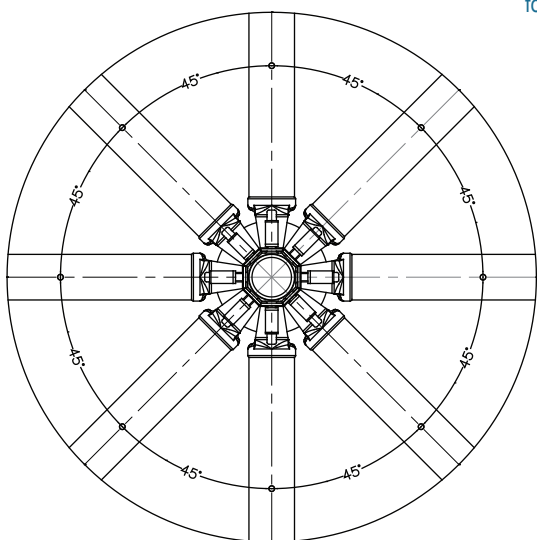

## Versatility of the Shorelok System

The Shorelok scaffold system enables safe and efficient reinforcement operations. Its modular design makes it adaptable for use as reinforcing scaffolding, stair towers, access scaffolding, and mobile scaffold towers in various locations.

Users can systematically choose legs, walings, diagonals, and decking boards to achieve different scaffold heights, bay lengths, and bay widths.

The Shorelok 48, offers a shoring capability with an infinite height adjustment and a working load-carrying capacity of up to 40kN per leg with horizontal lifts of 1.5m.

# Shorelok-48 Standards

The Shorelok verticals are available to suit any propping or access application economically. The innovative rosette is set at 50cm vertical intervals for maximum versatility in use. Two series of standards are produced to suit various applications.

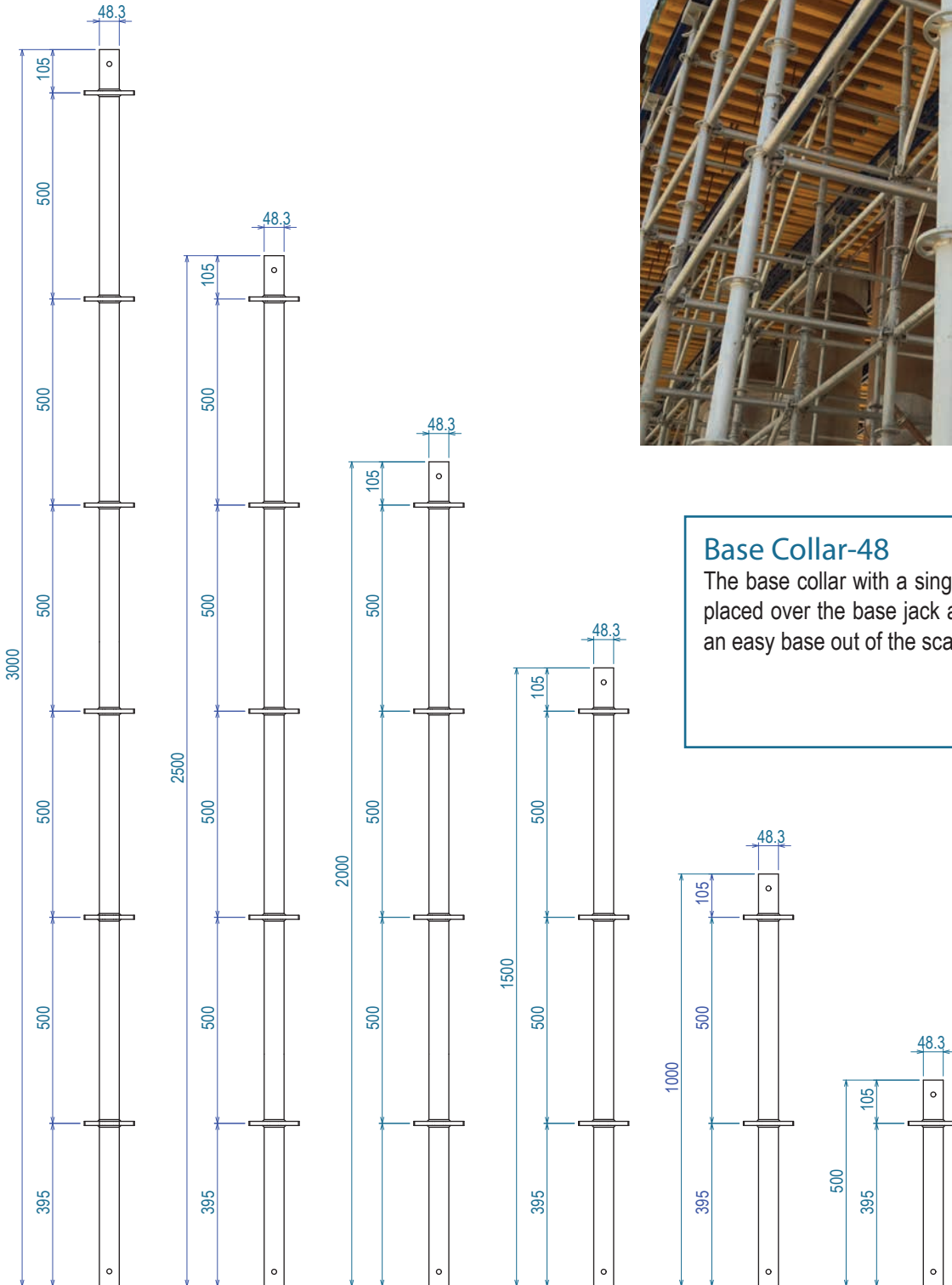

## Base Collar-48

The base collar with a single rosette is placed over the base jack and enables an easy base out of the scaffold.

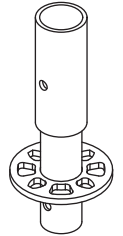

# Shorelok-48 Ledgers

Ledgers (Horizontals) are offered in a variety of standard lengths and are crafted with a 48.3mm tube diameter. If needed, custom lengths can be supplied. These standard-sized Ledgers are compatible for use with the two Standards series, i.e. 60 and 48 Standards.

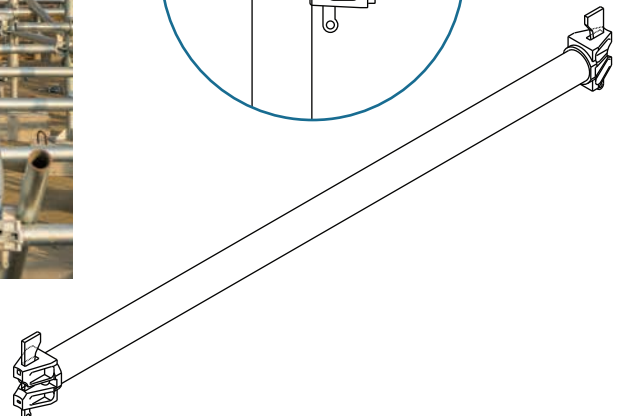
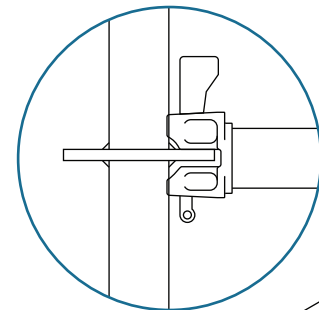
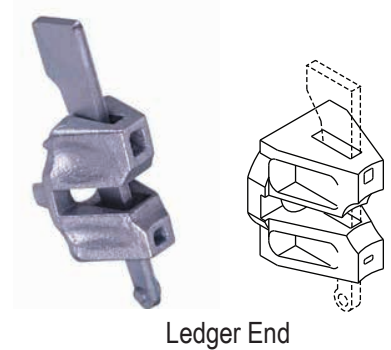
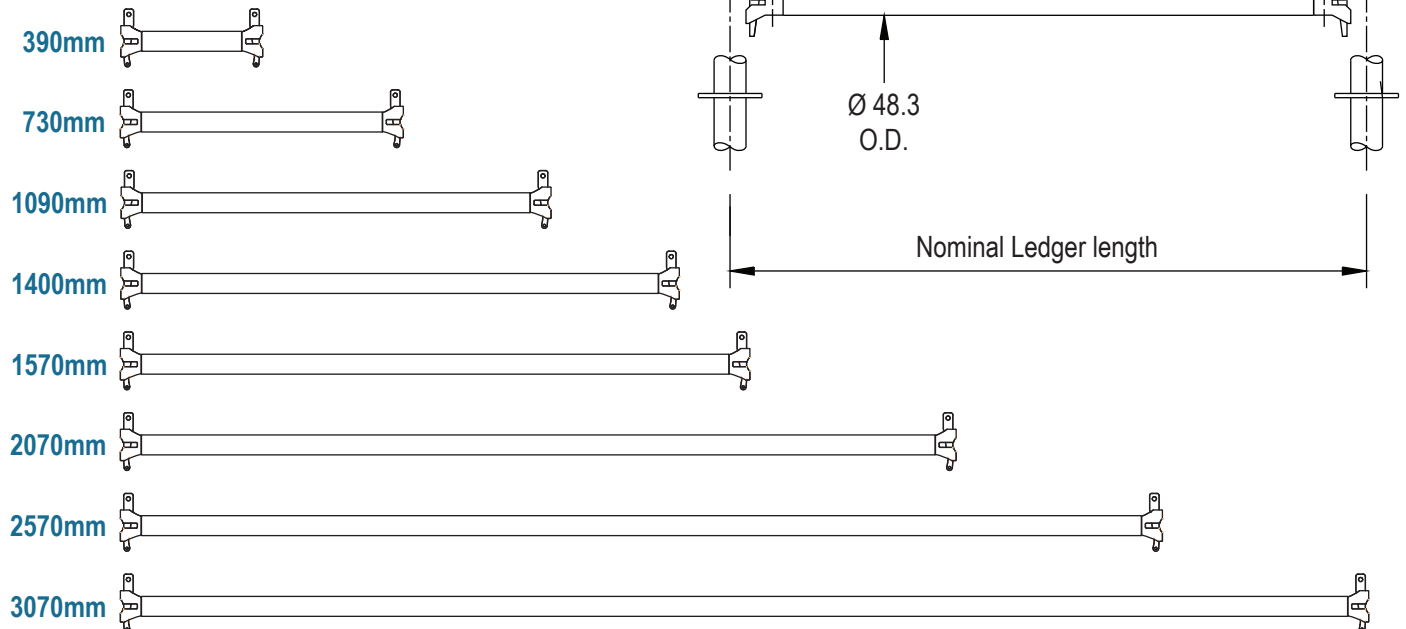

## Shorelok-48 Diagonal Brace

Diagonal Braces are made of a 48.3mm diameter tube, featuring a swivel ledger-end with wedges securely fastened at both ends, connecting them to the rosette on the Standard. These braces play a vital role in supplying both transverse and longitudinal bracing to fortify the scaffold structure. They are offered in a range of lengths to accommodate various combinations of bay widths and heights.

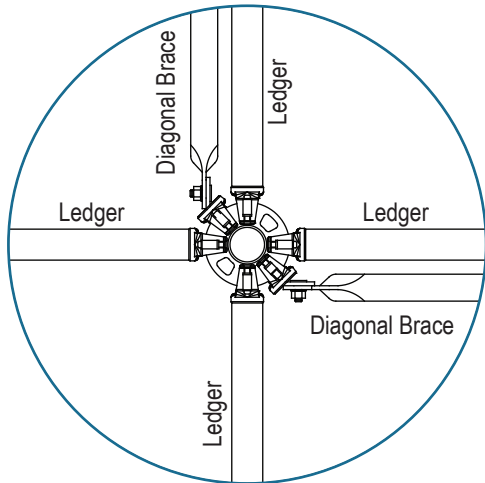

Diagonal Brace End

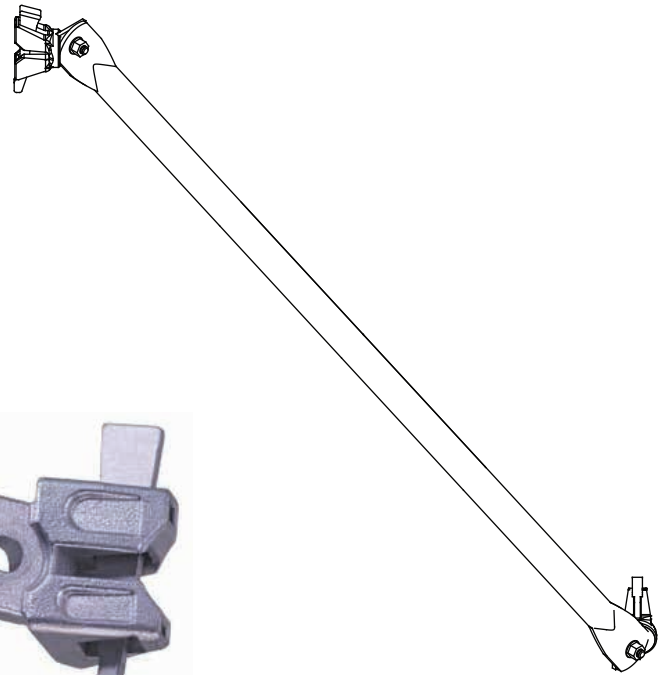

# Shorelok-48 Components

The Shorelok connector not only makes the assembly and dismantling of your scaffold particularly easy, but also saves you a lot of valuable time. The system only consists of a few basic components that are easy to store. Shorelok is a high-quality modular scaffolding system that allows you to work safely for decades with hardly any maintenance costs.

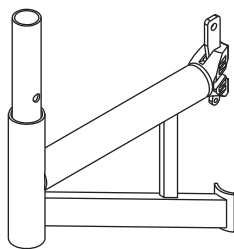

## Side Bracket

The side bracket can be used to expand the working platform. This expansion can be made by a one-board bracket or by a two-board bracket. When expanding scaffolds with brackets, check stability or anchoring against tilting!

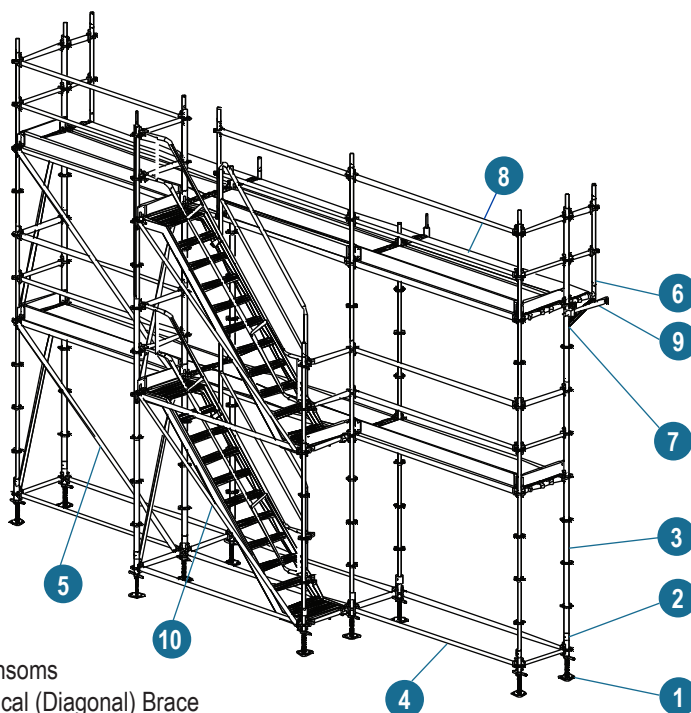

- 1) Base jack
- 2) Base collar
- 3) Standards
- 4) Ledgers / Transoms
- 5) Braces – Vertical (Diagonal) Brace
- 6) Side Brackets
- 7) Side Protection –ToeBoard
- 8) Platforms - Steel Deck
- 9) Accessories – Couplers
- 10) Access Stair, Outer guard rail, Inner guard rail

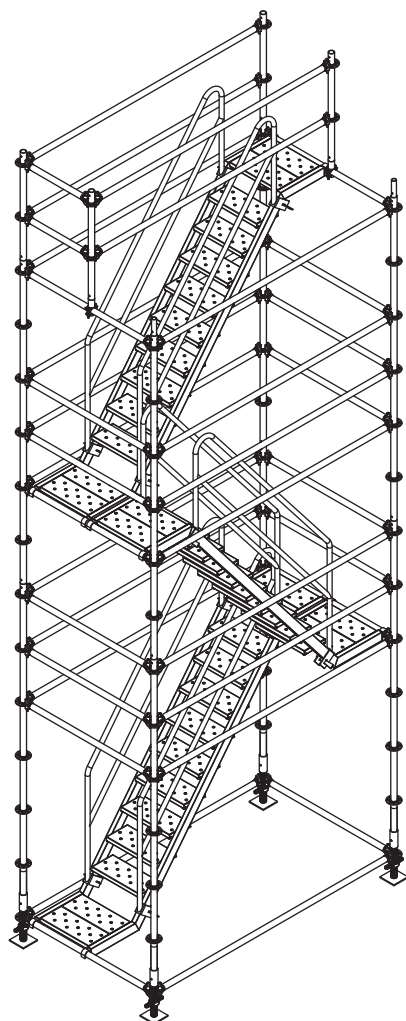

## Access Stair, Outer guard rail & Inner guard rail

For access to higher platforms, a stair access is recommended. The stairway is made out of aluminium or steel and can be easily handled by two people.

The outer and inner guardrail guides you in a safe way to the higher lifts of the scaffold.

Both guardrails are made out of steel.

The extended inner guardrail enables the closing of the top platform.

The end guardrail enables closing at the end of the scaffold.

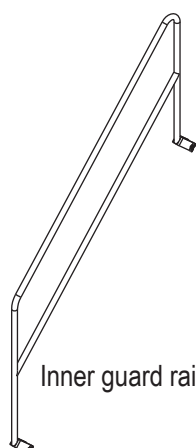

Inner guard rail

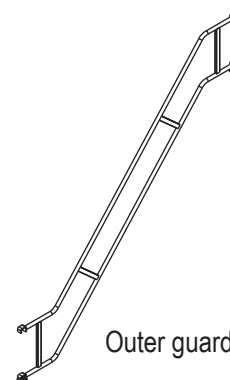

Outer guard rail





## Design, Approvals and Conformity





The loading capacity information for Shorelok access and shoring scaffolds has been determined through a static calculation methodology, which has been further validated by a destructive laboratory test. The components incorporated within the Shorelok scaffold system adhere to the standards and codes of practice as specified below:

- BS EN 12810-1:2003 'Facade scaffolds made of prefabricated components - Part 1: Product specifications'
- BS EN 12810-2:2003 'Facade scaffolds made of prefabricated components - Part 2: Particular methods of structural design'
- BS EN 12811-1:2003 'Temporary works equipment - Part 1: Scaffold performance requirements and general design'
- BS EN 12811-2:2004 'Temporary works equipment - Part 2: Information on materials'
- BS EN 12811-3:2002 'Temporary works equipment - Part 3: Load Testing'
- NASC (National Access & Scaffolding Confederation) 'System Product Code of Practice (CoP)'
- BS EN 1993-1:2005 (Eurocode 3 Design of steel structures)



# Classes of Access and Working Scaffolds

Scaffolds should be assembled according to the expected live load, which is directly related with the works that will be performed afterwards. According to the BS standard for facade scaffolds the following loading cases can be listed.

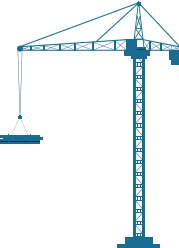
Class	Live load (kN/m <sup>2</sup> )	Duty	Typical loading examples
1	0.75	Very light duty	<p>Inspection, painting, light cleaning or access.</p>  <p>One worker</p>
2	1.50	Light duty	<p>Light maintenance works, painting, cleaning or access.</p>  <p>Two workers</p>
3	2.00	General purpose	<p>General maintenance works or access.</p>  <p>Two workers + 50 Kg of equipment and materials</p>
4	3.00	Heavy Duty	<p>Heavier maintenance works</p>  <p>Two workers + 100 Kg of equipment and materials</p>
5	4.50	Special purpose	<p>Heavy works with material storage</p> 
6	6.00	Special purpose	

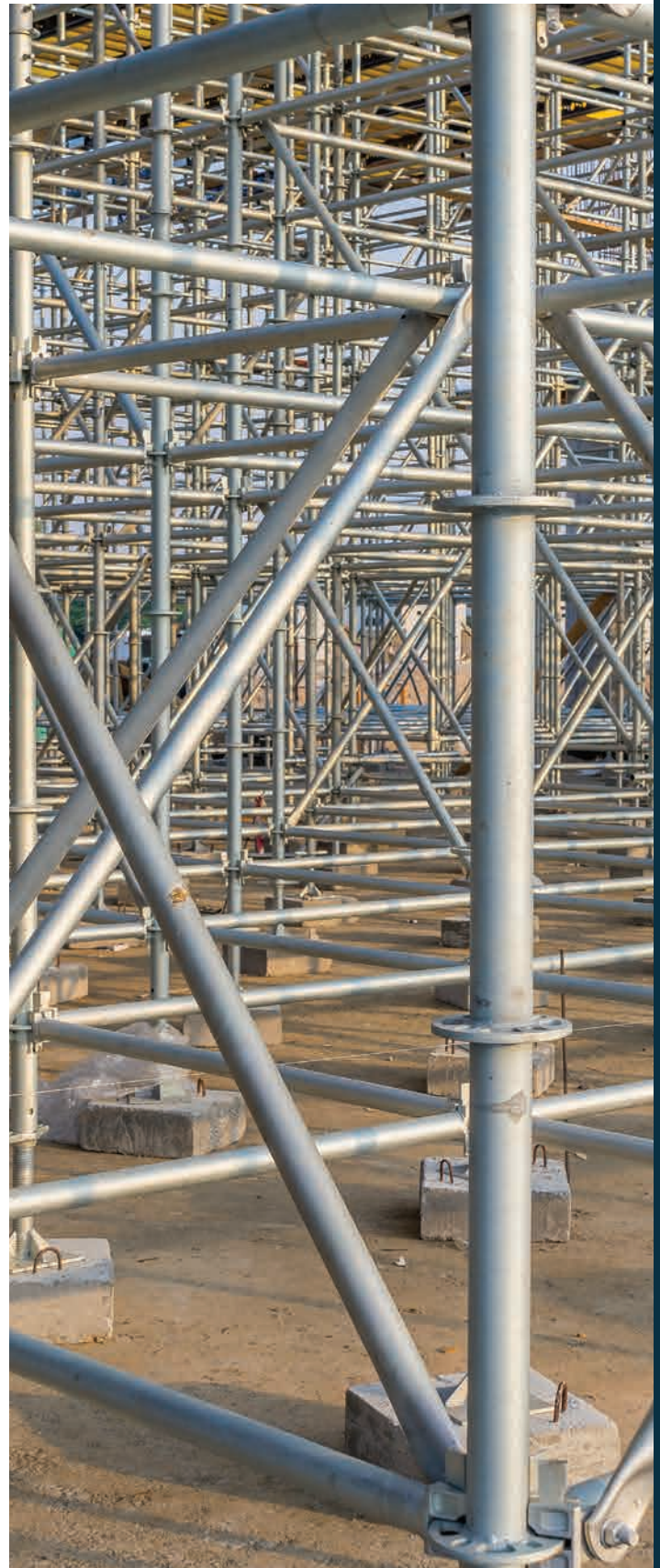

# Anchoring and Bracing

When erecting scaffolds in freestanding configurations, it's imperative to ensure their stability by anchoring them to a robust facade. Fundamentally, a scaffold, composed of loosely connected components, is inherently a "weak" structure. To fortify its structural integrity and ensure stability, additional specialized elements must be incorporated. The stabilization of facade scaffolds must be created in all the 4 following different sections:

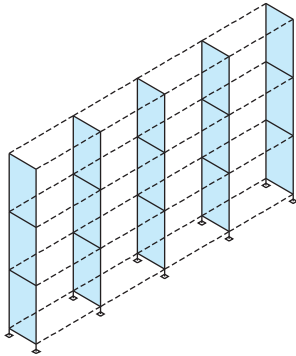

a) Stabilization of the sections perpendicular to the facade

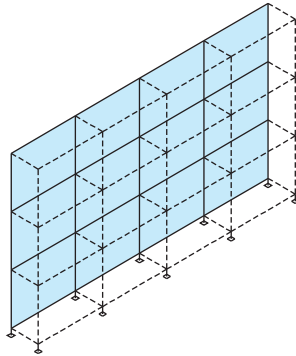

b) Stabilization of the inner section, parallel to the facade

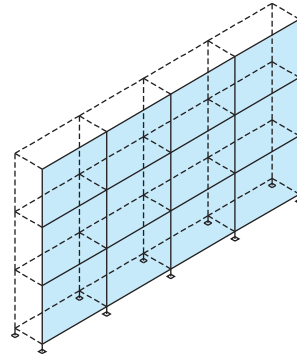

c) Stabilization of the outer section, parallel to the facade

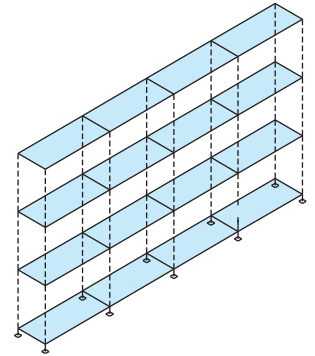

d) Stabilization of the horizontal sections of the scaffold

For stabilization of sections a) and b) **anchors** (or **tie members**) and **V-anchors** can be used, for section c) **vertical braces** and for sections d) **steel decks** or **horizontal braces**.

## Anchoring (Tie Member)

To ensure the stability of the scaffold faces perpendicular to the facade, it is essential to employ tie members, securing each row of standards. These tie members play a crucial role in ensuring both the overall stability of the scaffold, preventing it from turning over, and the local stability by reducing the risk of verticals (standards) buckling. A typical tie member comprises the following components:

- an anchoring tube with a special hook for fixation on the anchoring tool
- couplers to fix the anchoring tube to the standards of the scaffold
- an anchoring tool to fix the anchoring tube to a stable and strong façade

The tie members are mounted with couplers on the inner and outer standards, close (< 300mm) to the node point of the standard and ledgers.

The number of tie members needs to be established by calculation or must be according to a standard configuration.

The tie members need to be positioned on a regular pattern all over the scaffold. Depending on the required number of tie members we can mainly distinguish 4 different patterns, see figure below:

- 8 meter pattern and 4 meter on the outside standards
- 4 meter pattern or 4 meter staggered pattern
- 2 meter pattern, tie members at every 2 m node point

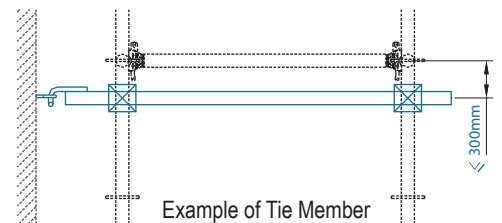

Example of Tie Member

**Note:** It's important to note that both the tie member and the anchoring foundation must consistently have the capacity to support the specified loads of the scaffold structure. These loads should be determined through on-site calculations and verification.

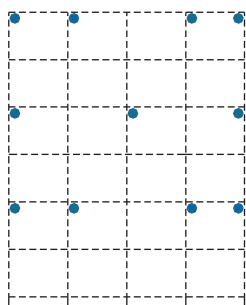
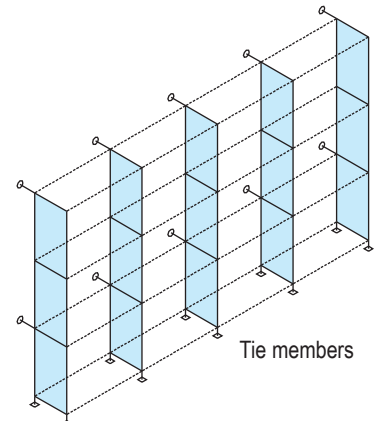

8m-pattern

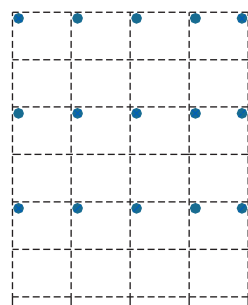

4m-pattern

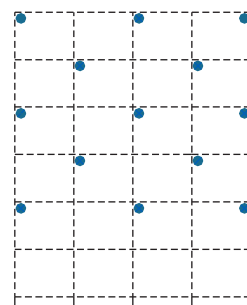

4m-staggered

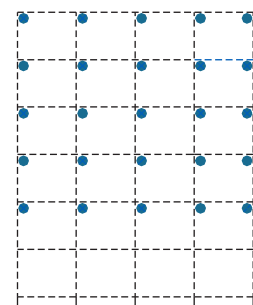

2m-pattern

Anchoring pattern

## Anchoring (V-Anchors)

When it's impractical to use Tie Members attached to both the inner and outer standards for stabilizing the inner section parallel to the facade, an alternative involves using tie members positioned at an angle of approximately 60 degrees, resembling V-anchors.

V-anchors have to be placed, depending on the imposed horizontal loads parallel to the facade, preferably at least at both ends of the scaffold.

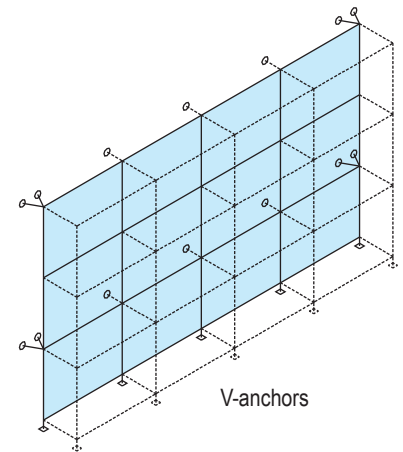

## Bracing

### Vertical bracing

For stabilizing the outer plane of the scaffold, parallel and perpendicular to the facade vertical braces can be used. Vertical braces are placed in at least every 5<sup>th</sup> bay on every lift and in every end bay perpendicular to the facade.

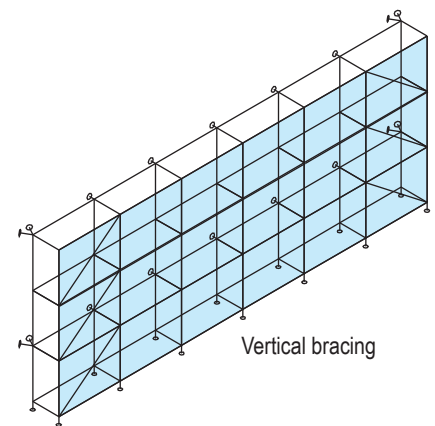

### Horizontal bracing

The horizontal sections of the scaffold are stabilized by either steel decks or in the case of platforms with wooden boards, by horizontal braces. These horizontal braces need to be placed in at least every 5<sup>th</sup> bay on every lift.

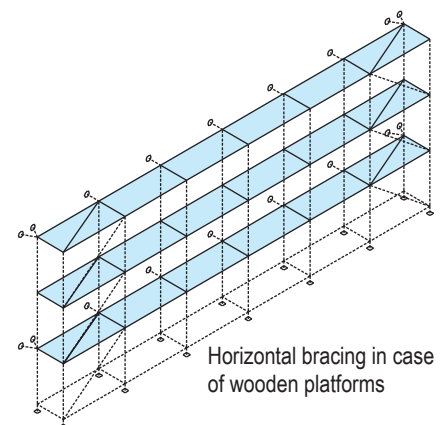

# Access to the Shorelok Scaffold

For access to the Shorelok scaffold there are two different possible solutions:

- 1) Access by special aluminium/plywood ladder platforms
- 2) Access by aluminium/steel stairways

## Access by ladder platforms

By assembling aluminium/plywood platforms with integrated ladders and special access doors, it is possible to get access to higher lifts. The ladder platforms are integrated into the working platforms. The maximum safe working load for the platform is  $200 \text{ kg/m}^2$  (EN12811-Class 3).

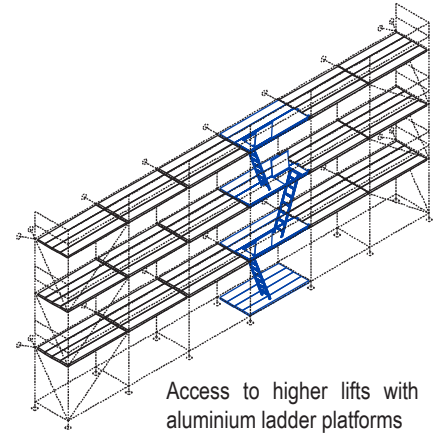

## Access by staircases

Another possibility to get access to the scaffold at higher lifts is to build a separate stair tower to the scaffold. Therefore the Shorelok system has two different solutions:

a) Building an extra bay of  $0,732 \times 2,572\text{m}$  on the outside of the scaffold. The stairs are mounted all in the same direction. You can access each lift of the scaffold, walk around on this lift and go to the following lift by the next stairs.

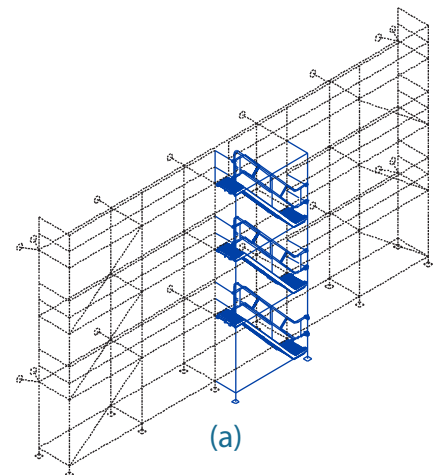

b) Building an extra bay of  $1,400 \times 2,572\text{m}$  against an access bay in the scaffold with a length of  $2,572\text{m}$ . The stairs are mounted in opposite directions and at the end of the stairs you can access the working platforms.

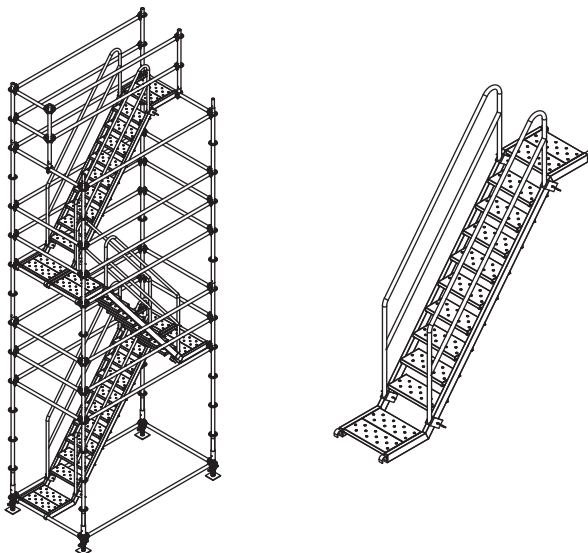
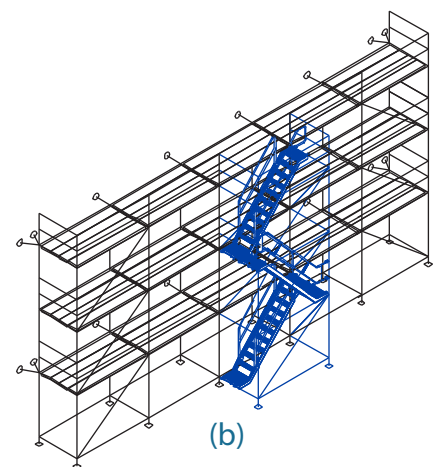

# Erection and dismantling of the scaffold

## Erection Procedure

1) Start the erection by laying the equipment components out in approximate positions.

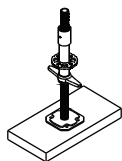

2) Place the base collar on the jack, see figure below, and use wooden planks under the base plates of the jacks to distribute the loads onto the ground.

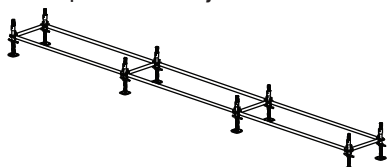

3) Repeat the procedure, placing base jacks in all four corners of the bay and connect them by using ledgers/transoms.

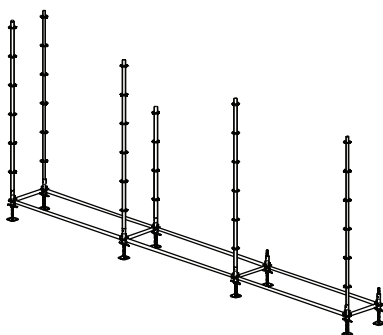

4) Starting at the highest point of the ground, level the base using a spirit level and by adjust the wing nut on the base jack. Lock all of the wedges in place by using a hammer. Now the base has been fixed you are ready for building the scaffold in height.

5) Insert standards into the base jacks, putting 3m standards on the outside and 2m on the inside of the scaffold.

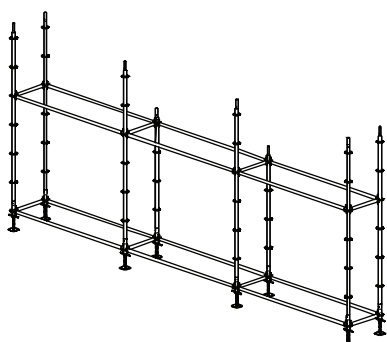

6) Start the erection of the first lift by fixing in place the ledgers and transoms.

**Note:** It may be necessary to place the steel decking on this base level to assist with the erection of the first lift.

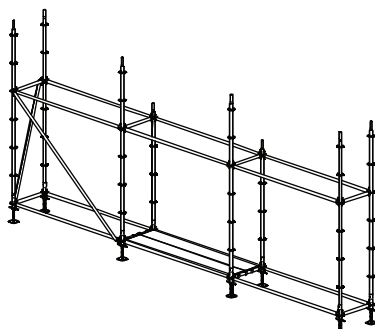

## Check Before Erection!

Before starting to erect a scaffold the following important points have to be considered:

- Be aware of the function of the scaffold
- Check all the loads that are imposed on the scaffold construction and its surroundings as well as the position of the loads on the scaffold and its surroundings.

The various loads are:

- Self weight of the scaffold construction
- Working loads on the working platforms
- Wind loads (eventual in combination with cladding)

c. Be aware of the line up of the scaffold in relation to the building

d. Check the ground conditions at the position of the scaffold

e. Check the condition of the façade at the positions of the anchors

f. Be convinced that all the loads can be supported by the scaffold construction

g. Be convinced that all the vertical loads of the scaffold can be supported by the ground and that all horizontal loads can be taken by the anchors and the façade of the building

h. Check the position of the scaffold in relation to the surroundings

i. Be aware of all the (local) safety regulations

j. Be aware of possible dangers of explosions or fire

k. Be aware that the scaffolding workers are trained to build the scaffold construction

l. Be aware that the scaffolding workers are fully instructed

m. Check the safety and function of all the tools that are used during erection

n. Check all the materials that are used in the scaffold construction. No damaged material is allowed to be used in any scaffolding construction!

7) After finishing the first lift you can build the next lifts. Very important during the erection of the next lifts is to work in a **safe way**. This means that before you can go to the next lift there needs to be a side protection system like guard rails. The Shorelok system gives you some solutions to have this side protection during erection, see figures a, b and c below.

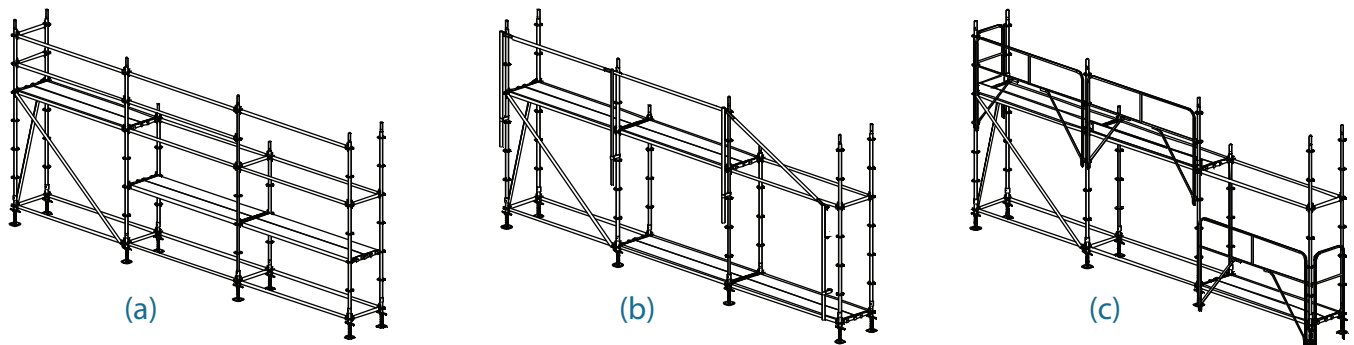

In figure (a) you can use standard Shorelok components by creating a temporary extra assembly floor on 1 meter height from the actual working floor. From this floor, you can mount the guard rails and the steel decks for the next floor.

Figure (b) shows the way of working with a temporary guard rail system. The temporary guard rail system exists of guard rail posts and guard rails. These components can be placed along the next floor from the lower lift. After entering the top floor you can assemble the definite guard rails and put the temporary guard rails to the next lift.

Figure (c) shows the use of definite assembly guard rails that can be placed from the lower lift directly for functioning on the next lift. After entering on the next lift you can place the definite guardrails for the next floor. In this case, you always are protected from falling down on the highest assembled floor. Besides side protection by guard rails, the erection people that work on unfinished lifts should wear safety harnesses and secure themselves to guard rails or standards.

8) Place steel decks at the first lift level from below.

**Note:** If using timber scaffold boards, intermediate transoms should be placed on the longitudinal ledgers. To get safe access to higher lifts of the scaffold, stairs, internal ladders or internal ladder platforms can be used. For mounting the stairs, an extra bay at the outside of the scaffold needs to be created.

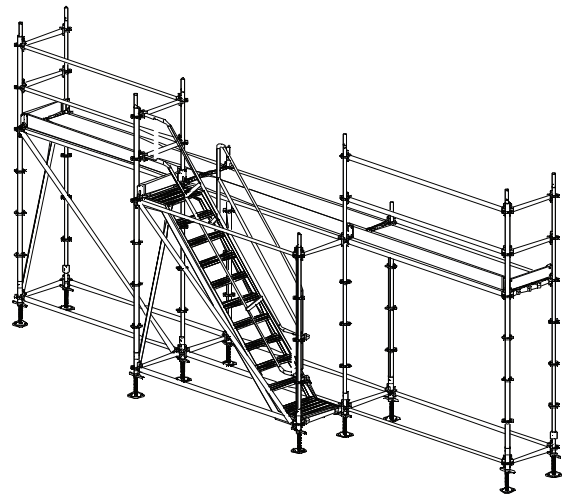
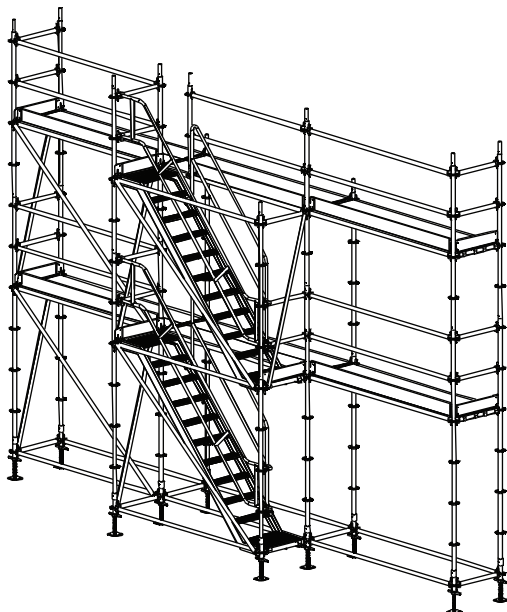

9) The next lift always needs to be decked out from below and a stair or ladder is used to access the next lift.

Ensure all working lifts have side protection consisting of double guard-rails and a toe board. Stairs, ladders or ladder platforms should be installed as the erection proceeds.

10) The scaffold should be physically tied into the facade of the building at the first available position, ideally at the second lift level. The tie pattern illustrated in this manual should be consulted. Each row of standards needs to be tied to the facade.

11) When the erection has been finished and the scaffold is ready for use then the “**scafftag**” must show the right instructions for using the scaffold.

## Use of Scaffold

It is required that during the use of the scaffold:

- 1) People who work on or with the scaffold are well informed about the maximum load of the scaffold. This is the maximum load on the platform as well as the maximum number of platforms that are allowed to be loaded.
- 2) Nobody should make modifications to the scaffold without the approval of the responsible scaffolding construction engineer.
- 3) The scaffold will not be used in severe weather conditions like storms, thunder and lightning, snow, hailstone or glazed frost.
- 4) The scaffold must be inspected on a regular base, especially after severe weather conditions.

## Dismantling Procedure

A safe dismantling of the Shorelok scaffold system relies upon the following basic operations and controls:

- 1) All platforms should be cleared of loose materials and the scaffold needs to be checked to ensure it is still in a correctly erected condition e.g. components or ties have not been removed or incorrectly re-fixed. The “scafftag” on the scaffold must show that the scaffold is not released for use anymore.
- 2) Dismantle the scaffold in the opposite order of erection. This means start from the top and go down, lift by lift.
- 3) Remove toe boards and guard-rails from the top platform.
- 4) Remove standards connected above platform level, having first checked that all components previously fixed to them have been removed.
- 5) Working from a temporary platform below the top platform, remove the (steel) planks from the top platform.
- 6) Remove all ledgers and transoms at the top platform level.
- 7) Working always from a temporary platform not more than 2m below the level from which components are to be removed, progressively dismantle the scaffold in the sequence described above.
- 8) Remove ties progressively as the scaffold is dismantled.

**Note:** ties should not be removed until they would prevent further dismantling of the scaffold.

- 9) Components should be lowered to the ground in a careful and safe way by passing from hand to hand down the scaffold or by means of an appropriate safe lowering method, such as by hand line, crane, hoist etc.

# Solutions by Shorelok System

Shorelok Scaffold offers a comprehensive array of solutions that can address a wide range of needs and challenges in the construction and scaffolding industry. Some of these solutions are described below

## Corner Solutions

Because of the flexibility of the system it is possible to create corner solutions in various ways. The next figures (1 to 5), show some of these solutions for right angle corners, using steel decks in the scaffold.

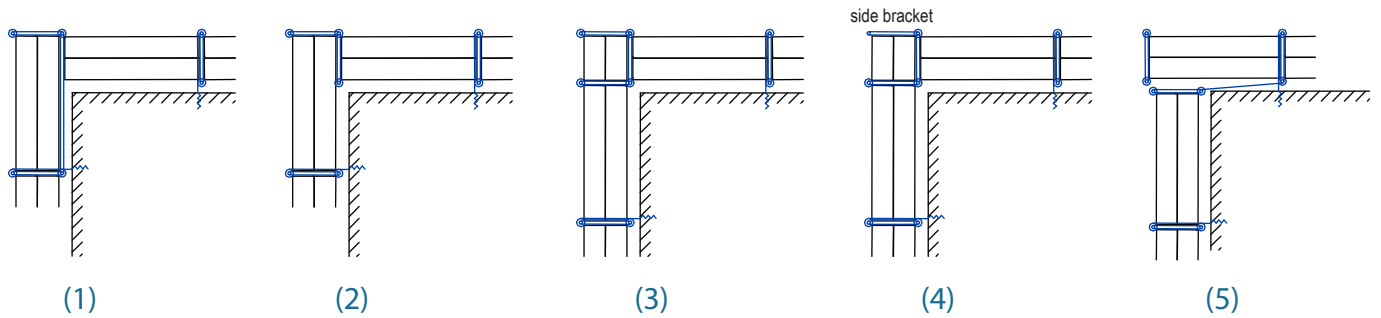

- 1) Corner solution with 2 standards, 1 transom and 1 double ledger
- 2) Corner solution with 3 standards, 2 transoms
- 3) Corner solution with 4 standards, 3 transoms
- 4) Corner solution with 3 standards, 2 transoms and 1 side bracket (2 steel planks)
- 5) Corner solutions with 4 standards, 2 transoms

## Platform Expansion

With the help of side brackets it is possible to expand the working floor and / or to fill gaps between the scaffold and the shape of the building.

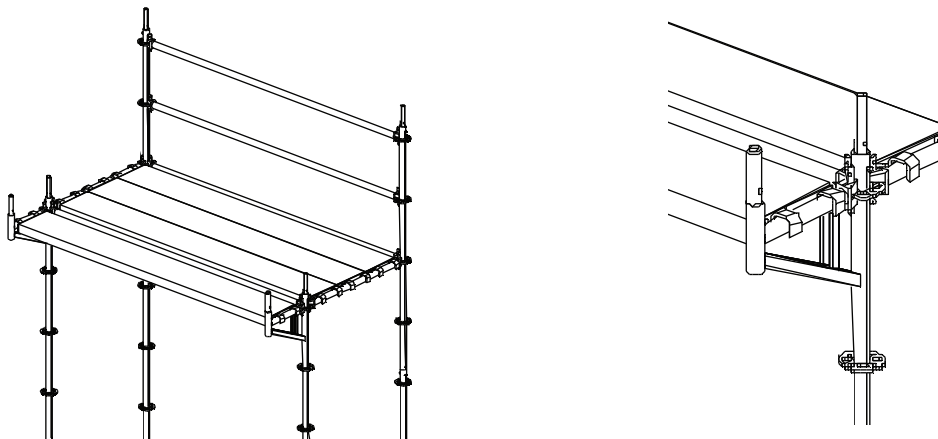

Side brackets are available in the width dimensions of (for 1 steel plank) and (for 2 steel planks). The side brackets are mounted on the standards by placing the welded wedge head construction of the bracket on the rosette of the standards. After hammering the wedge, the bracket is fixed to the scaffold and is able to take up loads.

When side brackets are used to create a wider working platform then it is necessary that the steel planks on the side brackets do have at least the same load capacity as the steel planks on the main floor.

## Bridging solutions

For creating underpasses in scaffold constructions, the Shorelok system can create a bridging construction with standard scaffolding accessories components like the base collar, standard and system diagonals. The bays just around the bridging construction need to be stiffened by Shorelok system diagonals.

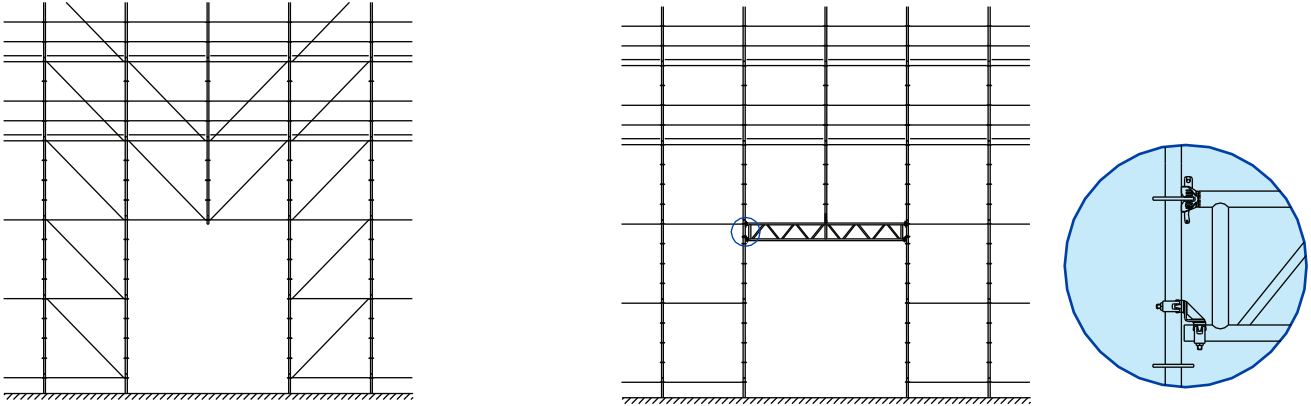

Another solution for creating a bridging, is with the help of Shorelok lattice girders and lattice girder couplers. The lattice girders are available in system lengths of 4,14m, 5,14m and 6,14m. With these lengths it is possible to bridge two bays of 2,07m, 2,57m or 3,07m.

The top side of the lattice girders is fixed to the standards by welded ledger end connections, the lower cord of the lattice girder is fixed to the standards by special lattice girder couplers. In order to prevent lattice girders from buckling because of the loading on the girder, it is necessary to stabilise the girders by stiffening the upper chord with the help of tubes and fittings, see figure below.

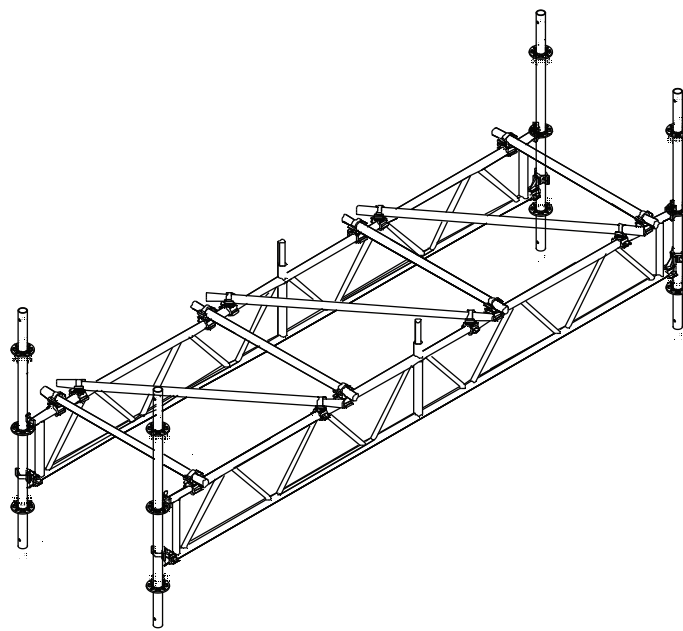

# Load capacity of Shorelok components

The scaffold's structural integrity, rigidity, and stability depend on the Shorelok node point's strength and the load-bearing capacity of various Shorelok components. This diagram illustrates how we assess the node point's rigidity and the load-carrying abilities of components such as the Shorelok base jack, standards, ledgers, diagonals, and steel decks. All of these loads are referred to as "Safe working loads" or "permissible loads." They are determined by dividing the design load by the prescribed load factor of 1.5.

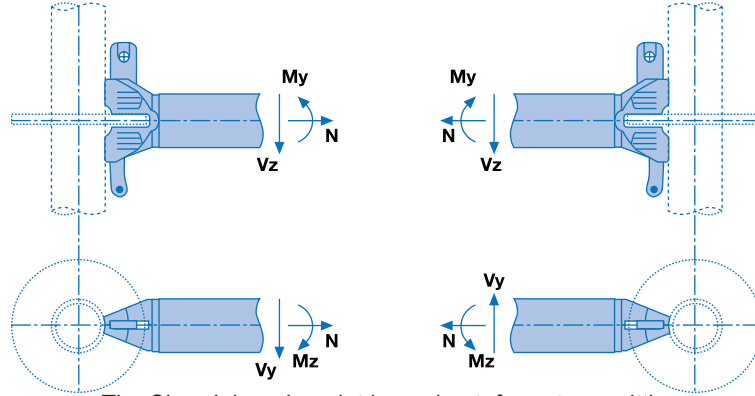

The Shorelok node point is a robust, force-transmitting connection capable of bearing loads from all directions.

## Bending moment on connection:

$$M_y = V \times a$$

$$\text{Perm. } M_y = \pm 80 \text{ kN.cm}$$

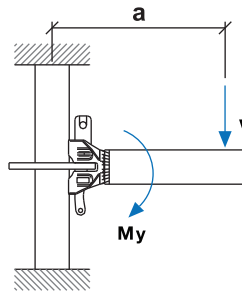

## Normal force on connection:

$$\text{Perm. } N = \pm 26 \text{ kN}$$

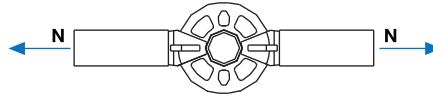

## Vertical load on rosette:

$$\text{Perm. } V_z = \pm 20 \text{ kN}$$

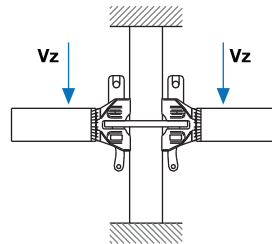

## Σ Vertical load on rosette:

$$\text{Perm. } V_z = \pm 70 \text{ kN}$$

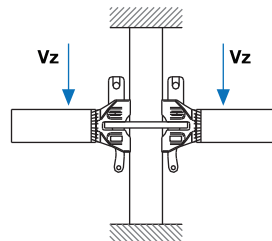

## Horizontal load on rosette:

$$\text{Perm. } V_y = \pm 10.5 \text{ kN}$$

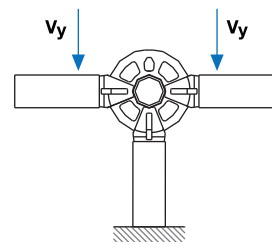

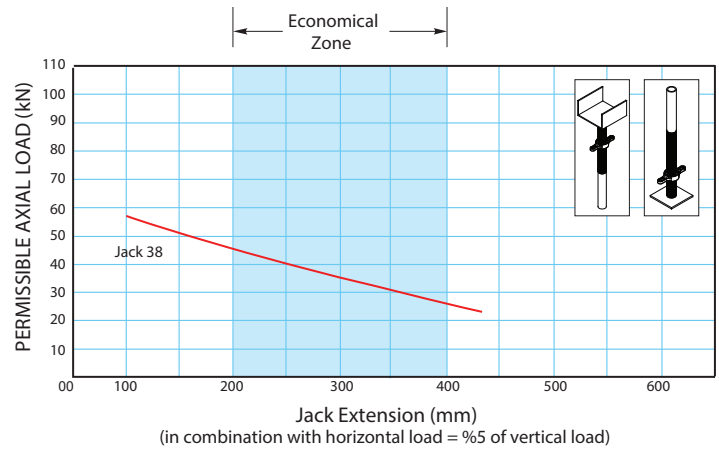
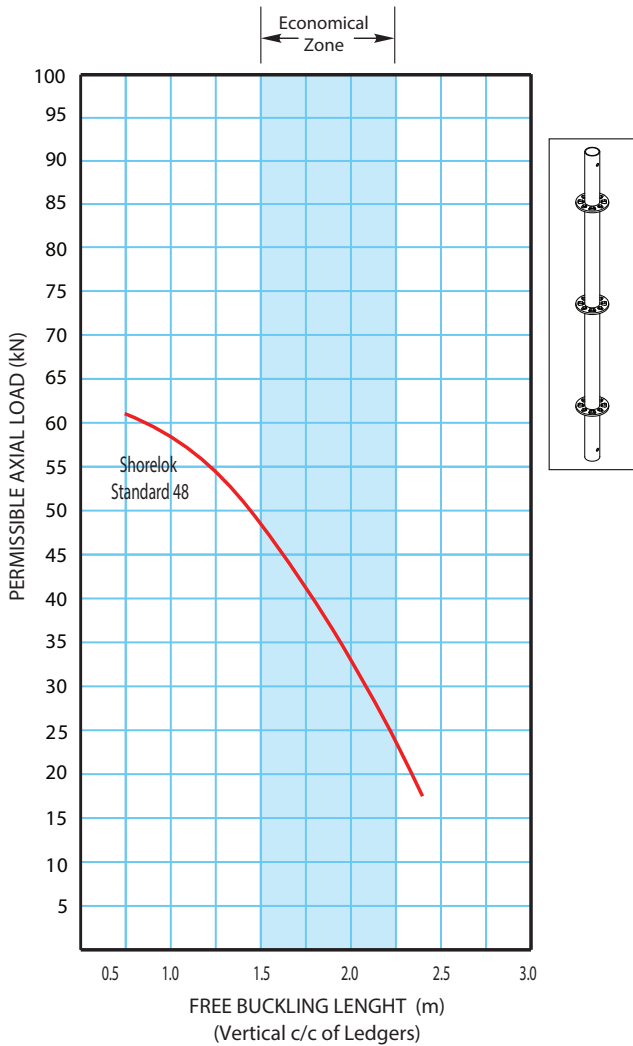

**Note:** The above mentioned load capacities for standards are indicated values. The vertical load capacity for standards depends on several other factors as:

- Lift height of the platforms
- Influence of horizontal loads
- Bracing and anchoring pattern of the scaffold.

For estimating the exact load capacity of standards, contact our engineer.

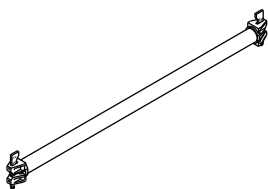

Load bearing capacity of Ledgers							
Bay length (m)	0.60	1.00	1.30	1.50	2.00	2.50	3.00
Uniformly distributed load (kN/m)	22	10	7	5.5	3.5	2.3	1.5
Point load in the middle (kN)	8	5.5	4.5	4.0	3.2	2.5	2.3

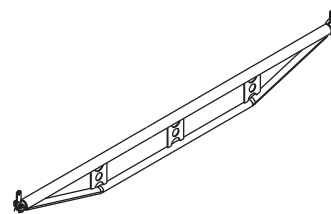

Load bearing capacity of Double Ledgers				
Bay length (m)	1.50	2,00	2,50	3,00
Uniformly distributed load (kN/m)	18	12	8	6
Point load in the middle (kN)	14	12	9.5	7.5

Shorelok 48 - Standard



Shorelok-48 Standard 050cm	2.10
Shorelok-48 Standard 100cm	4.50
Shorelok-48 Standard 150cm	6.75
Shorelok-48 Standard 200cm	9.00
Shorelok-48 Standard 250cm	11.25
Shorelok-48 Standard 300cm	13.50

Galvanised

Base Jack 38 - Hollow

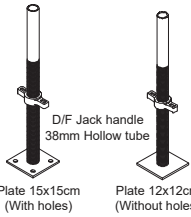

Base Jack 65cm H-E 12x12cm-38 Dia.	3.16
Base Jack 65cm H-E 15x15cm-38 Dia.	3.52
Base Jack 76cm H-E 12x12cm-38 Dia.	3.51
Base Jack 76cm H-E 15x15cm-38 Dia.	3.87

Finish: Galvanised

Base Collar

1.6

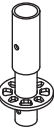

Galvanised

Base jack retention

2.0



Galvanised  
Height: 61.2 cm

Shorelok 48 - Ledger

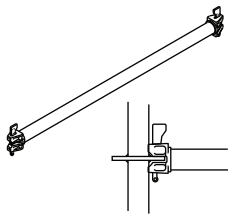

Ledger 0.39m	1.90
Ledger 0.73m	3.00
Ledger 1.09m	4.40
Ledger 1.40m	5.50
Ledger 1.57m	6.10
Ledger 2.07m	7.90
Ledger 2.57m	9.60
Ledger 3.07m	11.40

\*\* Special lengths available upon request

Finish: Galvanised  
Tube dia.: 48.3mm  
Ledger size defines as center to center of Standards (Verticals)

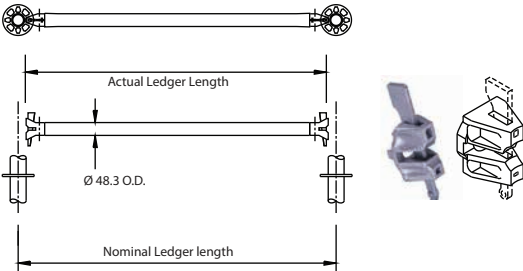

Intermediate Transom Tube

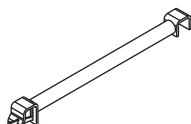

Intermediate transom tube 0.73m	3.60
Intermediate transom tube 1.09m	5.30
Intermediate transom tube 1.40m	6.40

\*\* Special lengths available upon request

Double Ledger

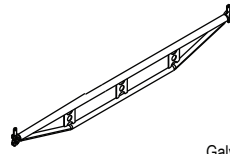

Galvanised

Double ledger 1.57m	9.9
Double ledger 2.07m	12.7
Double ledger 2.57m	15.8
Double ledger 3.07m	18.4

\*\* Special lengths available upon request

Diagonal Brace

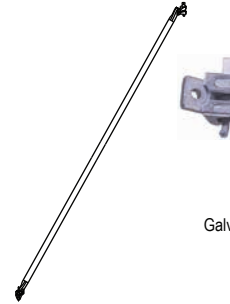

Galvanised

Diagonal 200/73cm	7.2
Diagonal 200/109cm	7.5
Diagonal 200/140cm	7.9
Diagonal 200/157cm	8.2
Diagonal 200/207cm	9.0
Diagonal 200/257cm	10.0
Diagonal 200/307cm	11.0

\*\* Special lengths available upon request

Steel-Deck

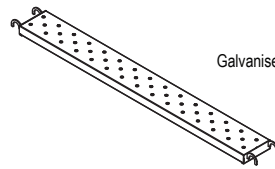

Galvanised

Steel-deck 32/73cm	6.9
Steel-deck 32/109cm	9.0
Steel-deck 32/140cm	11.0
Steel-deck 32/157cm	12.0
Steel-deck 32/207cm	15.2
Steel-deck 32/257cm	18.1
Steel-deck 32/307cm	21.1

Steel-deck 19/73cm	4.8
Steel-deck 19/109cm	7.2
Steel-deck 19/140cm	9.2
Steel-deck 19/157cm	10.5
Steel-deck 19/207cm	12.7
Steel-deck 19/257cm	15.5
Steel-deck 19/307cm	18.3

\*\* Special lengths available upon request

Steel Side Bracket

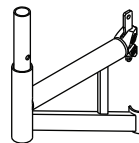

Galvanised

Bracket 0.39m	3.8
Bracket 0.73m	6.8

Wood Toeboard

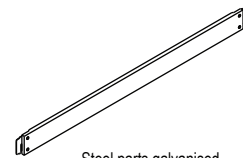

Steel parts galvanised  
Timber parts varnished yellow

Wood-toeboard 0.73m	2.8
Wood-toeboard 1.09m	3.9
Wood-toeboard 1.40m	4.9
Wood-toeboard 1.57m	5.5
Wood-toeboard 2.07m	7.2
Wood-toeboard 2.57m	8.8
Wood-toeboard 3.07m	10.3







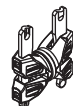



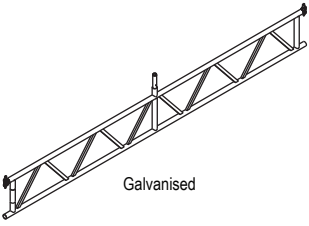





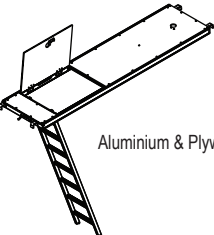
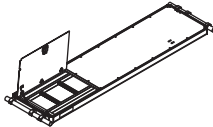

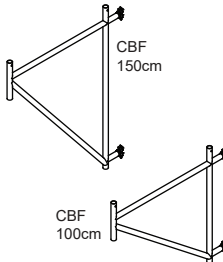

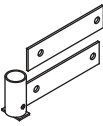

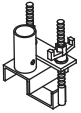
\*\* Special lengths available upon request

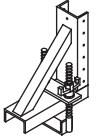

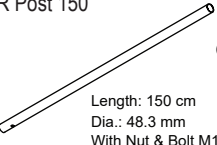

Twin ledger end coupler



1.6

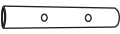
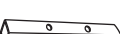

Galvanised  
Height: 10.8 cm



		Wt. (kg)	Code			Wt. (kg)	Code	
 <p>Lattice Girder</p> <p>Galvanised</p>	Lattice girder 4.14m	43.3		 <p>Hook-on ladder 2.24m</p> <p>Galvanised</p>		8.0		
	Lattice girder 5.14m	52.6						
	Lattice girder 6.14m	62.8						
 <p>Spigot clamp</p> <p>Galvanised Height: 29.3 cm</p>		1.3		 <p>Aluminium stairway 64/257cm</p> <p>Galvanised</p>	26.0		 <p>Aluminium stairway 64/307cm</p>	31.3
 <p>Lattice-girder coupler</p> <p>Galvanised Length: 20 cm Width-across: 22 mm</p>		1.5		 <p>Access Deck</p> <p>Aluminium &amp; Plywood</p>			 <p>AD w/ ladder 61/257cm</p> <p>AD w/ ladder 61/307cm</p>	21.0 24.5
 <p>Rosette</p> <p>Galvanised Width-across: 22 mm</p>		1.3		 <p>Shorelok 48 - Cantilever Beam Frame</p> <p>CBF 150cm</p> <p>SL Cantilever B. Frame 100cm</p> <p>SL Cantilever B. Frame 150cm</p> <p>CBF 100cm</p> <p>Finish: Galvanised Tube dia.: 48.3mm</p>				17.85 21.02
 <p>Castor wheel 10kN</p> <p>Galvanised</p>		7.0		 <p>Unified GR Bracket</p> <p>with 1no.M12X100 and 2no.M16X150 Bolt &amp; Nut</p> <p>Attached to the H20 Beams with M16x75 mm bolt &amp; nut (full threaded)</p>				3.65
 <p>Stairway guardrail adaptor</p> <p>Galvanised Height: 11.3 cm</p>		0.75		 <p>Universal GR Bracket</p> <p>Galvanised</p>				4.32
 <p>Inner railing 2.57m</p> <p>Galvanised</p>		10.6		 <p>Beam Frame</p> <p>Galvanised</p>				6.75
 <p>Outer railing 2.57m</p> <p>Galvanised</p>		13.8		 <p>Beam Fork</p> <p>Length: 171 cm Dia.: 48.3 mm</p> <p>Galvanised</p>				4.46
 <p>Outer railing 3.07m</p> <p>Galvanised</p>		18.7		 <p>GR Post 150</p> <p>Galvanised</p> <p>Length: 150 cm Dia.: 48.3 mm With Nut &amp; Bolt M12 x100</p>				3.57
 <p>Inner railing extended 2.57m</p> <p>Galvanised</p>		12.2						
 <p>Inner railing extended 3.07m</p> <p>Galvanised</p>		14.3						
 <p>Front railing 2.57m</p> <p>Galvanised Length: 68 cm</p>		6.1						







		Wt. (kg)	Code
<b>Spigot Connector</b>			
	GS Spigot Connector Round with Bolts:E	0.98	
	GS Spigot Connector Square with Bolts:E	0.74	
	GS Spigot Connector W/ washer:E	0.70	
	GS Spigot Connector W/ washer & Bolts:E	0.84	
	Attached to the standards with M9x75 mm bolt & nut (half threaded)		
<b>Bolt, Nut and Washer</b>			
	M10 X75	0.07	
	M12x40	0.10	
	M12x80 (Carriage)	0.09	
	M12x130(H/ Thread)	0.17	
	M14x100	0.15	
	M16x40	0.14	
	M16x100	0.20	
	M16x100 (G10)	0.25	
	M16x150	0.33	
	M10x100	0.08	
	M6x40	0.01	
	M10x30	0.04	
	M12x100 (H/Thread)	0.14	

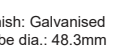

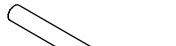
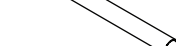
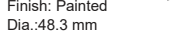

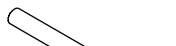
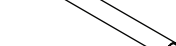
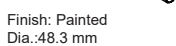

		Wt. (kg)	Code
<b>Shorelok 48 - Beam Bracket</b>			
	SL60/48- Beam Bracket 100cm	6.71	
	SL60/48- Beam Bracket 150cm	8.49	
Finish: Galvanised Tube dia.: 48.3mm			



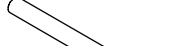
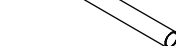

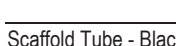

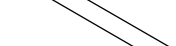
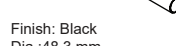
		Wt. (kg)	Code
<b>Transom</b>			
	Transom 039cm	2.25	
	Transom 073cm	4.40	
	Transom 109cm	5.45	
	Transom 140cm	6.65	
	Transom 157cm	7.15	
	Transom 200cm	8.52	
	Transom 250cm	10.20	
Finish: Galvanised Tube dia.: 48.3mm			



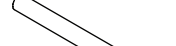
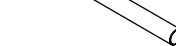
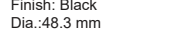

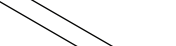
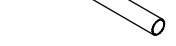
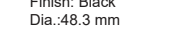

		Wt. (kg)	Code
<b>U-Head Adj. 38 - Hollow</b>			
	U-Head Adj. 38H:65 cm:10x10x15 E	4.59	
	U-Head Adj. 38H:65 cm:10x17x15 E	5.06	
	U-Head Adj. 38H:65 cm:10x17x20 E	5.91	
	U-Head Adj. 38H:65 cm:10x19x20 E	6.09	
	U-Head Adj. 38H:65 cm:10x21x20 E	6.27	
	U-Head Adj. 38H:76 cm:10x10x15 E	4.95	
	U-Head Adj. 38H:76 cm:10x17x15 E	5.42	
	U-Head Adj. 38H:76 cm:10x17x20 E	6.27	
	U-Head Adj. 38H:76 cm:10x19x20 E	6.45	
	U-Head Adj. 38H:76 cm:10x21x20 E	6.62	
Finish: Galvanised			



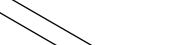
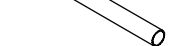

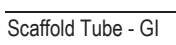

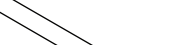
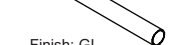
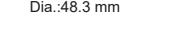

		Wt. (kg)	Code
<b>Anchor Plate</b>			
	Anchor Plate 30 cm	3.2	
	Anchor Plate 60 cm	4.3	
	Anchor Plate 150 cm	7.5	
	Anchor Plate 180 cm	8.5	
Finish: Galvanised Tube dia.: 48.3mm			

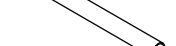
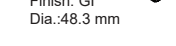





		Wt. (kg)	Code
<b>Shorelok 48 - Cantilever Beam Frame Scaffold Tube - Painted</b>			
<b>M.D. Tube</b>			
	Scaffold Tube 100 cm MD	2.28	FSTP20100
	Scaffold Tube 150 cm MD	3.42	FSTP20150
	Scaffold Tube 200 cm MD	4.57	FSTP20200
	Scaffold Tube 250 cm MD	5.71	FSTP20250
	Scaffold Tube 300 cm MD	6.85	FSTP20300
	Scaffold Tube 350 cm MD	7.99	FSTP20350
	Scaffold Tube 400 cm MD	9.13	FSTP20400
	Scaffold Tube 450 cm MD	10.27	FSTP20450
	Scaffold Tube 500 cm MD	11.42	FSTP20500
	Scaffold Tube 550 cm MD	12.56	FSTP20550
	Scaffold Tube 600 cm MD	13.70	FSTP20600
Finish: Painted Dia.:48.3 mm			

		Wt. (kg)	Code
<b>H.D. Tube</b>			
	Scaffold Tube 100 cm HD	3.35	FSTP30100
	Scaffold Tube 150 cm HD	5.03	FSTP30150
	Scaffold Tube 200 cm HD	6.70	FSTP30200
	Scaffold Tube 250 cm HD	8.38	FSTP30250
	Scaffold Tube 300 cm HD	10.05	FSTP30300
	Scaffold Tube 350 cm HD	11.73	FSTP30350
	Scaffold Tube 400 cm HD	13.41	FSTP30400
	Scaffold Tube 450 cm HD	15.08	FSTP30450
	Scaffold Tube 500 cm HD	16.76	FSTP30500
	Scaffold Tube 550 cm HD	18.43	FSTP30550
	Scaffold Tube 600 cm HD	20.11	FSTP30600
Finish: Painted Dia.:48.3 mm			

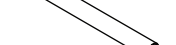
		Wt. (kg)	Code
<b>Scaffold Tube - Black</b>			
<b>M.D. Tube</b>			
	Scaffold Tube 100 cm MD	2.28	FSTN20100
	Scaffold Tube 150 cm MD	3.42	FSTN20150
	Scaffold Tube 200 cm MD	4.57	FSTN20200
	Scaffold Tube 250 cm MD	5.71	FSTN20250
	Scaffold Tube 300 cm MD	6.85	FSTN20300
	Scaffold Tube 350 cm MD	7.99	FSTN20350
	Scaffold Tube 400 cm MD	9.13	FSTN20400
	Scaffold Tube 450 cm MD	10.27	FSTN20450
	Scaffold Tube 500 cm MD	11.42	FSTN20500
	Scaffold Tube 550 cm MD	12.56	FSTN20550
	Scaffold Tube 600 cm MD	13.70	FSTN20600
Finish: Black Dia.:48.3 mm			

		Wt. (kg)	Code
<b>H.D. Tube</b>			
	Scaffold Tube 100 cm HD	3.35	FSTN30100
	Scaffold Tube 150 cm HD	5.03	FSTN30150
	Scaffold Tube 200 cm HD	6.70	FSTN30200
	Scaffold Tube 250 cm HD	8.38	FSTN30250
	Scaffold Tube 300 cm HD	10.05	FSTN30300
	Scaffold Tube 350 cm HD	11.73	FSTN30350
	Scaffold Tube 400 cm HD	13.41	FSTN30400
	Scaffold Tube 450 cm HD	15.08	FSTN30450
	Scaffold Tube 500 cm HD	16.76	FSTN30500
	Scaffold Tube 550 cm HD	18.43	FSTN30550
	Scaffold Tube 600 cm HD	20.11	FSTN30600
Finish: Black Dia.:48.3 mm			

		Wt. (kg)	Code
<b>Scaffold Tube - GI</b>			
<b>M.D. Tube</b>			
	Scaffold Tube 100 cm MD	2.28	FSTG20100
	Scaffold Tube 150 cm MD	3.42	FSTG20150
	Scaffold Tube 200 cm MD	4.57	FSTG20200
	Scaffold Tube 250 cm MD	5.71	FSTG20250
	Scaffold Tube 300 cm MD	6.85	FSTG20300
	Scaffold Tube 350 cm MD	7.99	FSTG20350
	Scaffold Tube 400 cm MD	9.13	FSTG20400
	Scaffold Tube 450 cm MD	10.27	FSTG20450
	Scaffold Tube 500 cm MD	11.42	FSTG20500
	Scaffold Tube 550 cm MD	12.56	FSTG20550
	Scaffold Tube 600 cm MD	13.70	FSTG20600
Finish: GI Dia.:48.3 mm			

		Wt. (kg)	Code
<b>H.D. Tube</b>			
	Scaffold Tube 100 cm HD	3.35	FSTG30100
	Scaffold Tube 150 cm HD	5.03	FSTG30150
	Scaffold Tube 200 cm HD	6.70	FSTG30200
	Scaffold Tube 250 cm HD	8.38	FSTG30250
	Scaffold Tube 300 cm HD	10.05	FSTG30300
	Scaffold Tube 350 cm HD	11.73	FSTG30350
	Scaffold Tube 400 cm HD	13.41	FSTG30400
	Scaffold Tube 450 cm HD	15.08	FSTG30450
	Scaffold Tube 500 cm HD	16.76	FSTG30500
	Scaffold Tube 550 cm HD	18.43	FSTG30550
	Scaffold Tube 600 cm HD	20.11	FSTG30600
Finish: GI Dia.:48.3 mm			

### H20 Timber Beam



Moment: 5.00 kN.m  
Shear: 11 kN  
Area: 18.87 cm<sup>2</sup>  
E.I.=500 kNm<sup>2</sup>

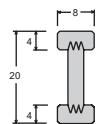

Supports are rounded at the end for damage protection. Web-three layer crosswise laminated solid timber panel.

	Wt. (kg)	Code
H20 Beam 125cm with End Cup	6.39	FTBH20125E
H20 Beam 145cm with End Cup	7.29	FTBH20145E
H20 Beam 165cm with End Cup	8.29	FTBH20165E
H20 Beam 180cm with End Cup	9.09	FTBH20180E
H20 Beam 225cm with End Cup	11.29	FTBH20225E
H20 Beam 245cm with End Cup	12.39	FTBH20245E
H20 Beam 265cm with End Cup	13.39	FTBH20265E
H20 Beam 290cm with End Cup	14.59	FTBH20290E
H20 Beam 295cm with End Cup	14.89	FTBH20295E
H20 Beam 330cm with End Cup	16.59	FTBH20330E
H20 Beam 360cm with End Cup	18.09	FTBH20360E
H20 Beam 390cm with End Cup	19.59	FTBH20390E
H20 Beam 450cm with End Cup	22.59	FTBH20450E
H20 Beam 490cm with End Cup	24.59	FTBH20490E
H20 Beam 590cm with End Cup	29.59	FTBH20590E
H20 Beam 1190cm with End Cup	59.59	FTBH201190E
H20 Beam 125cm	6.30	FTBH20125
H20 Beam 145cm	7.20	FTBH20145
H20 Beam 165cm	8.20	FTBH20165
H20 Beam 180cm	9.00	FTBH20180
H20 Beam 225cm	11.20	FTBH20225
H20 Beam 245cm	12.30	FTBH20245
H20 Beam 265cm	13.30	FTBH20265
H20 Beam 290cm	14.50	FTBH20290
H20 Beam 295cm	14.80	FTBH20295
H20 Beam 330cm	16.50	FTBH20330
H20 Beam 360cm	18.00	FTBH20360
H20 Beam 390cm	19.50	FTBH20390
H20 Beam 450cm	22.50	FTBH20450
H20 Beam 490cm	24.50	FTBH20490
H20 Beam 590cm	29.50	FTBH20590
H20 Beam 1190cm	59.50	FTBH201190

### Wooden Plank - (Timber Board)

T W L

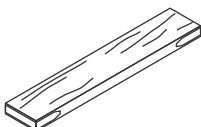

WP 38.0x225x1000 MM (Laminated)	4.62	FWP3802301000L
WP 38.0x225x1500 MM (Laminated)	6.22	FWP3802301500L
WP 38.0x225x2000 MM (Laminated)	9.23	FWP3802302000L
WP 38.0x225x2500 MM (Laminated)	11.54	FWP3802302500L
WP 38.0x225x3000 MM (Laminated)	13.85	FWP3802303000L
WP 38.0x225x3900 MM (Laminated)	18.00	FWP3802303900L
WP 38.0x225x3900 mm	13.70	FWP3802253900
WP 38.0x225x3000 mm	10.54	FWP3802253000
WP 38.0x225x2500 mm	8.78	FWP3802252500
WP 38.0x225x2000 mm	7.03	FWP3802252000
End Strip for Wooden Board Protection	0.05	XXESWBPC

### Marine Plywood 244x122

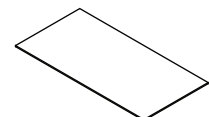

Marine Plywood 12.00X2440X1220 mm	19.50	FMPW0120A01
Marine Plywood 18.00X2440X1220 mm	29.00	FMPW0180A01

### Aluminum Beam T150 (Without Timber)

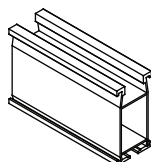

Finish: Mill Finish

Aluminum Beam T150  
(without Timber)

Moment of resistance: 13.00 kN.m  
Area: 18.87 cm<sup>2</sup>  
Inertia xx: 574.3 cm<sup>4</sup>  
Inertia yy: 147.4 cm<sup>4</sup>  
Section modulus Zxx: 75.36 cm<sup>3</sup>  
Young's Modulus 69000 N/mm<sup>2</sup>  
Weight: 5.80 kg/m (with Timber)  
5.05 kg/m (without Timber)  
Timber Wt. = 0.75 kg/m

Alum T150-050cm	2.6	FABTW050
Alum T150-075cm	3.8	FABTW075
Alum T150-100cm	5.1	FABTW100
Alum T150-125cm	6.4	FABTW125
Alum T150-150cm	7.7	FABTW150
Alum T150-175cm	8.9	FABTW175
Alum T150-200cm	10.2	FABTW200
Alum T150-225cm	11.5	FABTW225
Alum T150-250cm	12.8	FABTW250
Alum T150-275cm	14.0	FABTW275
Alum T150-300cm	15.3	FABTW300
Alum T150-325cm	16.6	FABTW325
Alum T150-350cm	17.9	FABTW350
Alum T150-375cm	19.1	FABTW375
Alum T150-400cm	20.4	FABTW400
Alum T150-425cm	21.7	FABTW425
Alum T150-450cm	23.0	FABTW450
Alum T150-475cm	24.2	FABTW475
Alum T150-500cm	25.5	FABTW500
Alum T150-525cm	26.8	FABTW525
Alum T150-550cm	28.1	FABTW550
Alum T150-575cm	29.3	FABTW575
Alum T150-600cm	30.6	FABTW600

### Aluminum Beam S150

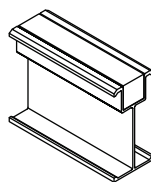

Finish: Mill Finish

Aluminum Beam S150  
(Timber Size 38x38mm)

Weight: 3.95 kg/m (with Timber)  
3.20 kg/m (without Timber)  
Timber Wt. = 0.75 kg/m

	Wt. (kg)	Code
Alum S150-050cm	1.9	FABST050
Alum S150-075cm	2.9	FABST075
Alum S150-100cm	3.9	FABST100
Alum S150-125cm	4.9	FABST125
Alum S150-150cm	5.8	FABST150
Alum S150-175cm	6.8	FABST175
Alum S150-200cm	7.8	FABST200
Alum S150-225cm	8.7	FABST225
Alum S150-250cm	9.7	FABST250
Alum S150-275cm	10.7	FABST275
Alum S150-300cm	11.6	FABST300
Alum S150-325cm	12.6	FABST325
Alum S150-350cm	13.6	FABST350
Alum S150-375cm	14.6	FABST375
Alum S150-400cm	15.5	FABST400
Alum S150-425cm	16.5	FABST425
Alum S150-450cm	17.5	FABST450
Alum S150-475cm	18.4	FABST475
Alum S150-500cm	19.4	FABST500
Alum S150-525cm	20.4	FABST525
Alum S150-550cm	21.3	FABST550
Alum S150-575cm	22.3	FABST575
Alum S150-600cm	23.3	FABST600

### Aluminum Beam S150 (Without Timber)

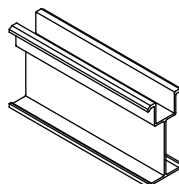

Aluminum Beam S150  
(without Timber)

Finish: Mill Finish

Moment of resistance: 6.80 kN.m  
Area: 11.96 cm<sup>2</sup>  
Inertia xx: 356 cm<sup>4</sup>  
Inertia yy: 43.764 cm<sup>4</sup>  
Section Modulus Zxx: 47.15 cm<sup>3</sup>  
Young's Modulus: 69000 N/mm<sup>2</sup>  
Weight: 3.95 kg/m (with Timber)  
3.20 kg/m (without Timber)  
Timber Wt. = 0.75 kg/m

Alum S150-050cm	1.6	FABSW050
Alum S150-075cm	2.3	FABSW075
Alum S150-100cm	3.1	FABSW100
Alum S150-125cm	3.9	FABSW125
Alum S150-150cm	4.7	FABSW150
Alum S150-175cm	5.5	FABSW175
Alum S150-200cm	6.3	FABSW200
Alum S150-225cm	7.0	FABSW225
Alum S150-250cm	7.8	FABSW250
Alum S150-275cm	8.6	FABSW275
Alum S150-300cm	9.4	FABSW300
Alum S150-325cm	10.2	FABSW325
Alum S150-350cm	11.0	FABSW350
Alum S150-375cm	11.7	FABSW375
Alum S150-400cm	12.5	FABSW400
Alum S150-425cm	13.3	FABSW425
Alum S150-450cm	14.1	FABSW450
Alum S150-475cm	14.9	FABSW475
Alum S150-500cm	15.7	FABSW500
Alum S150-525cm	16.4	FABSW525
Alum S150-550cm	17.2	FABSW550
Alum S150-575cm	18.0	FABSW575
Alum S150-600cm	18.8	FABSW600

### Aluminum Beam T150

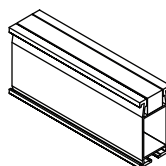

Finish: Mill Finish

Aluminum Beam T150  
(Timber Size 38x38mm)

Weight: 5.80 kg/m (with Timber)  
5.05 kg/m (without Timber)  
Timber Wt. = 0.75 kg/m

Alum T150-050cm	2.9	FABTT050
Alum T150-075cm	4.4	FABTT075
Alum T150-100cm	5.9	FABTT100
Alum T150-125cm	7.3	FABTT125
Alum T150-150cm	8.8	FABTT150
Alum T150-175cm	10.2	FABTT175
Alum T150-200cm	11.7	FABTT200
Alum T150-225cm	13.2	FABTT225
Alum T150-250cm	14.6	FABTT250
Alum T150-275cm	16.1	FABTT275
Alum T150-300cm	17.6	FABTT300
Alum T150-325cm	19.0	FABTT325
Alum T150-350cm	20.5	FABTT350
Alum T150-375cm	21.9	FABTT375
Alum T150-400cm	23.4	FABTT400
Alum T150-425cm	24.9	FABTT425
Alum T150-450cm	26.3	FABTT450
Alum T150-475cm	27.8	FABTT475
Alum T150-500cm	29.3	FABTT500
Alum T150-525cm	30.7	FABTT525
Alum T150-550cm	32.2	FABTT550
Alum T150-575cm	33.6	FABTT575
Alum T150-600cm	35.1	FABTT600

### Scaffold Couplers

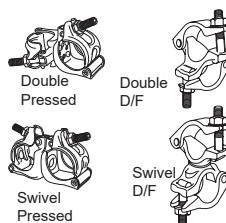

Double Coupler 1.5"x1.5" (Pressed)	0.73	XFGCDP4848
Swivel Coupler 1.5"x1.5" (Pressed)	0.68	XFGCSP4848
Double Coupler 1.5"x1.5" (D/F)	0.99	XFGCDD4848
Swivel Coupler 1.5"x1.5" (D/F)	1.10	XFGCSD4848
Double Coupler 2.0"x1.5" (D/F)	1.20	XFGCDD6048
Swivel Coupler 2.0"x1.5" (D/F)	1.25	XFGCSD4860

**Phone:**

+971 4 886 2855

**Email Us:**

[sales@scaffco.com](mailto:sales@scaffco.com)

**Address:**

P.O. BOX 18234 Jebel Ali Dubai – UAE

**Phone:**

+971 2 550 0688

**Email Us:**

[sales@scaffco.com](mailto:sales@scaffco.com)

**Address:**

PO. BOX 41851- Abu Dhabi – UAE