

SCAFFFRAME SYSTEM

OVERVIEW & METHOD STATEMENT

Exceptional Load-Bearing Capability Coupled
with Maximum Safety

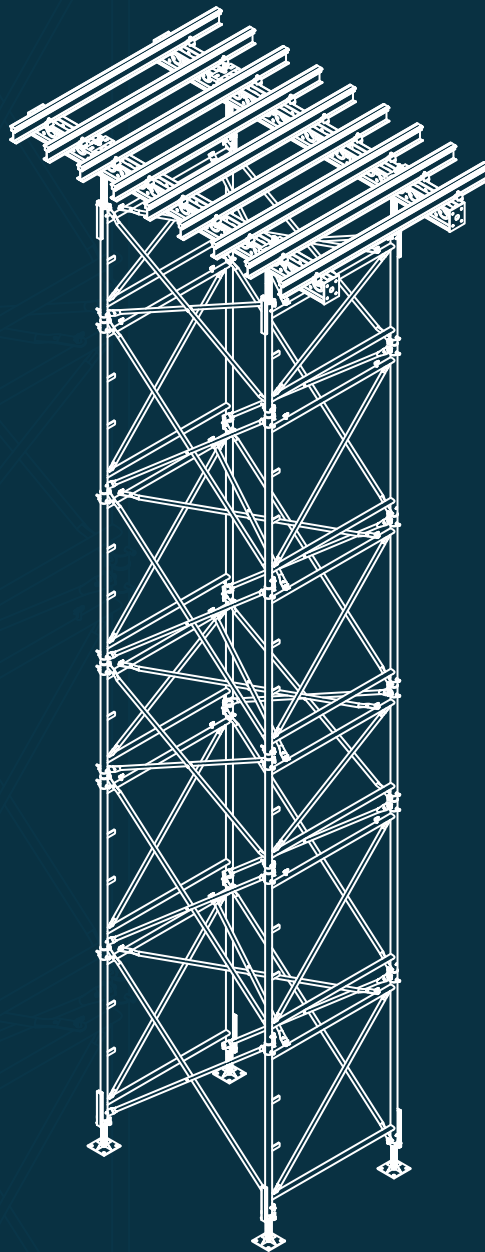



Disclaimer:

While every effort has been made to ensure the accuracy of the information in this catalogue, we cannot accept responsibility for any errors which may occur as a result of reliance on the contents of this catalogue and are not liable for any loss of any nature that may be incurred as a result of such reliance. Details of any of the products may change without prior notice.

The customer must ensure that 'good practice' is adopted on site by competent persons and that the products shown in this catalogue are erected, used and stripped in accordance with the relevant Codes of Practice, international standards and the local authorities regulations. This catalogue does not contain any design detail but lists and depicts the items available under this product range. The responsibility for design is the responsibility of the customer. Please, contact Scaffco's engineer for any technical inquiries.

In our commitment to delivering top-tier products with optimal performance across diverse construction conditions, and aligned with our continuous product development initiatives, it's crucial to acknowledge that the components of the Scafframe system outlined in this manual, along with their geometry and specifications, may differ from the latest version presently in circulation for this system. As part of our strategy for product development aimed at improving performance, modifications may be implemented without prior notice.

تنويه:

في حين تم بذل كل جهد ممكن لضمان دقة المعلومات الواردة في هذا الدليل، لا يمكن أن تقبل شركة سكايفكو المسؤولية عن أي أخطاء قد تحدث نتيجة الاعتماد على أي من محتويات هذا الدليل، والشركة غير مسؤولة عن أي خسارة من أي نوع قد يتم تكبدها نتيجة لاعتماد محتويات هذا الدليل. تحتفظ الشركة بحق تغيير أي من المنتجات او التفاصيل دون إشعار مسبق.

يجب على العملاء التأكد من أن يتم تبني الممارسات الصحيحة في الموقع من ناحية استخدام المعدات المذكورة في هذا الدليل. كذلك يجب على العملاء التأكد من كفاءة وحرفية الأشخاص القائمين على تركيب واستعمال وتفكيك عناصر الأنظمة وان تكون هذه العمليات متطابقة مع المتطلبات والمعايير المذكورة في المواصفات الدولية ذات العلاقة ولوائح وتعليمات السلطات المحلية. هذا الدليل لا يحتوي على أية تفاصيل تخص التصميم ولكن يصف مكونات الأنظمة بشكل تصويري ويعطي فكرة عن عناصر الأنظمة المتاحة في إطار هذه المجموعة من المنتجات. الرجاء الاتصال بمهندس شركة سكايفكو للحصول على أي استفسارات فنية تخص المنتجات المذكورة في هذا الدليل.

في إطار التزامنا بتقديم منتجات عالية الجودة تعمل بفعالية في ظروف البناء المتنوعة، و بما يتوافق مع مبادراتنا المستمرة لتطوير المنتج، من المهم أن نوضح هنا الى أن مكونات نظام Scafframe الموضحة في هذا الدليل، قد تختلف عن الإصدار الأحدث للمنتج المتداول حالياً لهذا النظام. قد يتم تنفيذ هذه التعديلات دون إشعار مسبق.

Exceptional Load-Bearing Capability Coupled with Maximum Safety

Scafframe, the load-bearing tower, stands out for its exceptional load-bearing capacity and cost-effectiveness in day-to-day construction applications. Scafframe combines the strength of the steel frames with high-speed assembly, impressive load-bearing capacity, and exceptional versatility, making it the preferred choice for demanding construction challenges.

The Scafframe stands out not only for its adaptability and strength but also for its reliability across diverse construction contexts. Its ability to cater to the specific demands of varied scenarios underscores its versatility, making it a dependable choice for construction professionals navigating the complexities of different project requirements. Whether supporting the creation of sturdy bridges, facilitating efficient building construction, or contributing to the structural integrity of industrial and power-station projects, the Scafframe proves to be an invaluable asset in the construction industry.

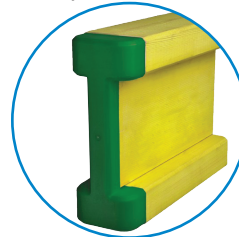
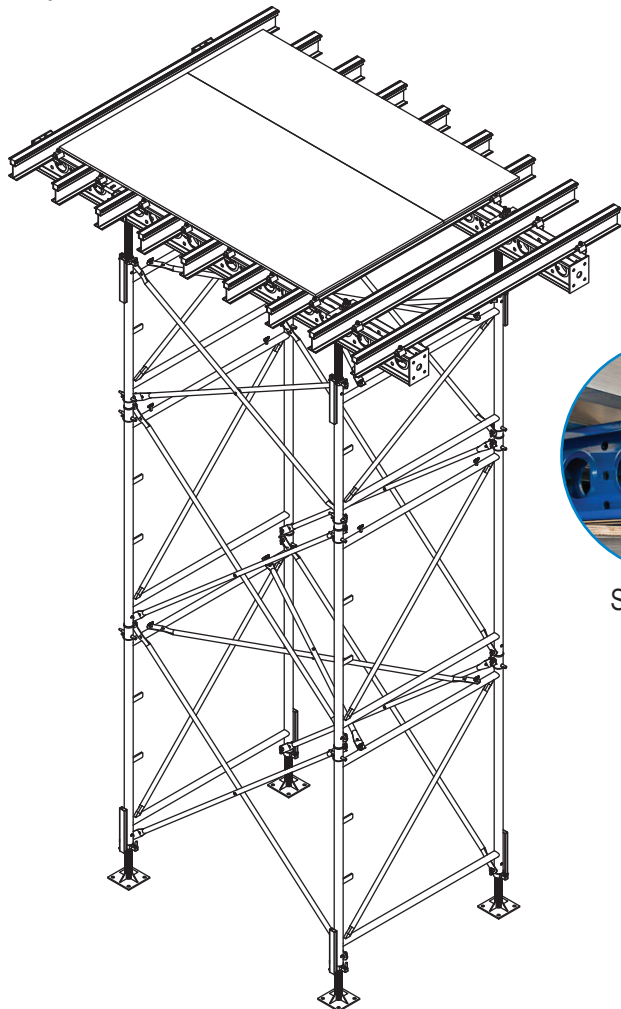

H20 Timber Beam

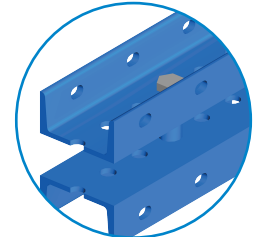

Steel Waling
W12 or W10

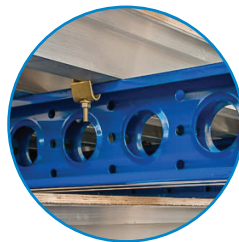

Steel Soldier

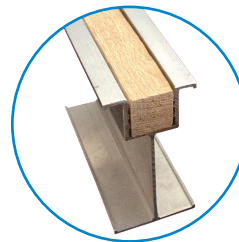

Alum. Beam S150

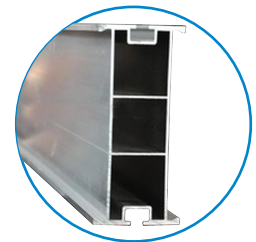

Alum. Beam T225

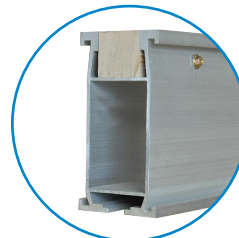

Alum. Beam T150



LVL Beam

Time saving: 30% time saving compared with assembly of traditional scaffolding made of separate standards and ledgers.

Low number of components: The shoring frames serve as replacements for standards, ledgers, and diagonal braces, resulting in significant time savings during both assembly and dismantling processes. Additionally, this design leads to a reduction in the overall number of components, streamlining the construction workflow and enhancing efficiency.

Horizontal assembly on the ground: The assembly of the shoring tower can be conducted at ground level, following which the tower is easily positioned with the assistance of a crane.

Simple bolt free connection: Completely toolless system, the shoring frames can be jointed with spigot connector. The frames will be secured against lift-off by using spring locked pins.

Compatible system: The Scafframe shoring system exhibits compatibility with a range of formwork girders, including H20 timber beams, Aluminium Beams, Steel Walers, Soldiers and LVL beams.

1- Overview of the Scafframe system

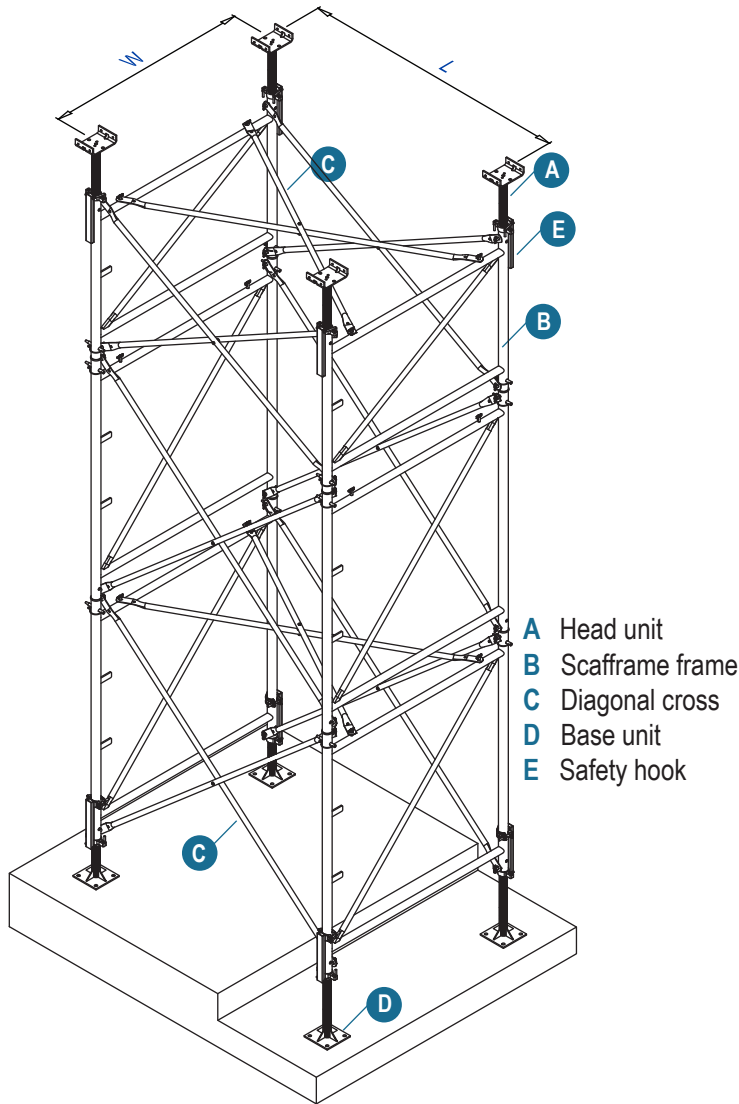

L = Inter-frame spacing = 60* / 100 / 150 / 175 / 200 / 250 / 300cm
 W = Frame width = 152cm
 * only for 1.20 and 0.90m frames

Base units (D) & Safety hook (E)

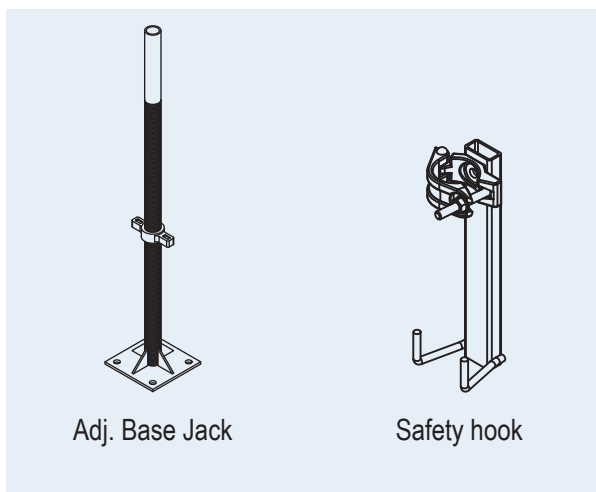

Head units (A)

<p>Adjustable 4-way Head</p> <p>Suitable for utilization with one or two H20 beams, the primary beams are securely anchored to ensure they remain stable and cannot tip over.</p>	<p>Adjustable U-Head</p> <p>For securing the primary beams, such as steel walings or steel girders.</p>
---	---

Frames (B)

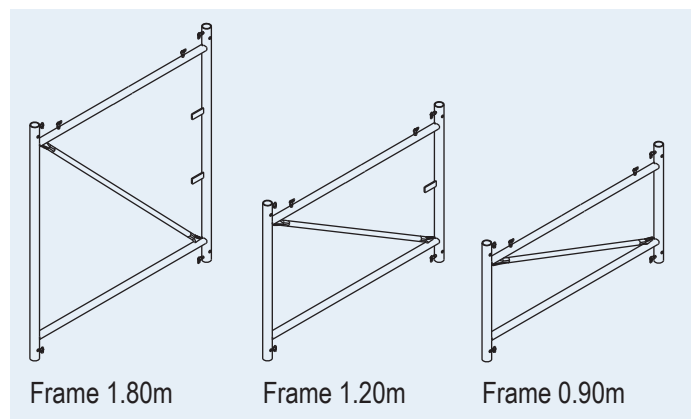

Diagonal crosses (C)

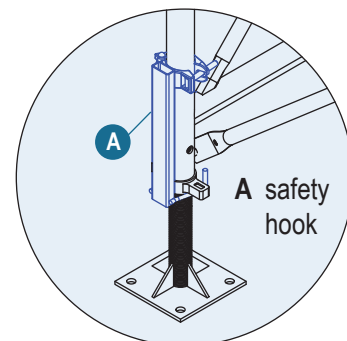
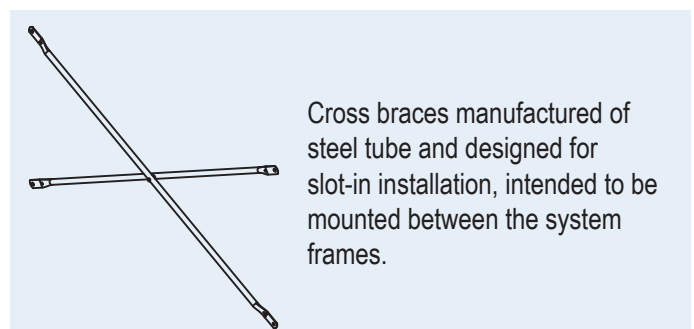

The safety hook is utilized to fasten the adjustable U-head or adjustable base jack to the frame under the following circumstances:

- During the assembly of tower frames in a horizontal position.
- When the tower frames are lifted by a crane.

2- Interconnecting the system frames

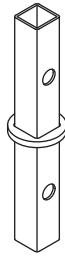
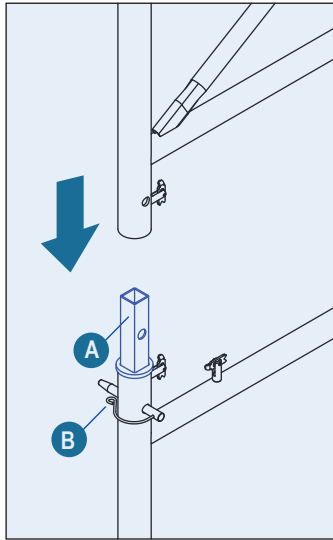

A Spigot Connector
B Spring locked connecting pin 16mm

Spring locked connecting pin (16mm)

In situations where potential tension is present, the tension connection between connected frames requires the use of a "spring locked connecting pin (16mm)." The following scenarios necessitate the utilization of the "spring locked connecting pin (16mm)":

- During the horizontal assembly of tower frames.
- When the tower frames are lifted by a crane.
- If there are forces acting upon the tower that induce tensile stress.

**Permitted tensile force:
22kN**

The connection between the frames stacked vertically is established through the use of a spigot connector featuring an integrated stop-ring. The remarkable extension of this spigot connector, reaching a length of 15cm into each frame, eliminates the requirement for additional pin-type safety locks when erecting or dismantling tower frames in the upright position.

Connecting the couplers to the Scafframe

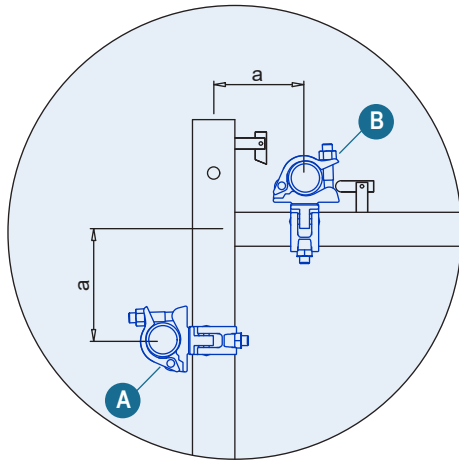

a ... max. 16cm
A Double or swivel coupler (48)-(60)mm
B Double or swivel coupler (48)mm

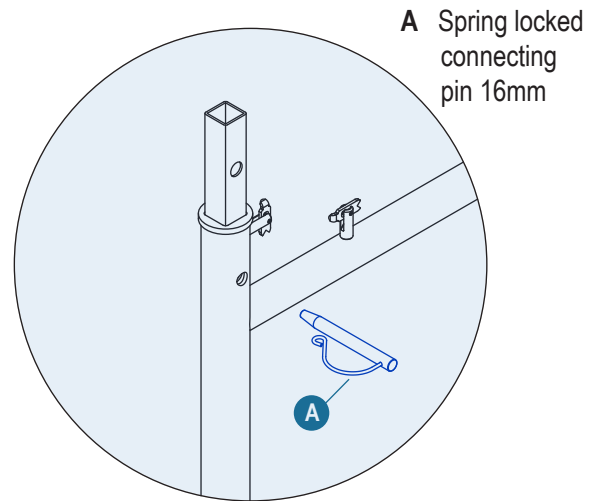

A Spring locked connecting pin 16mm

Attachment point for personal fall-arrest set

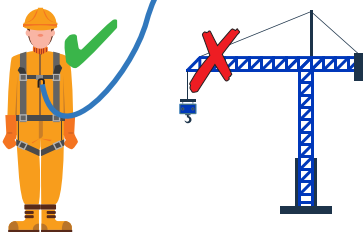
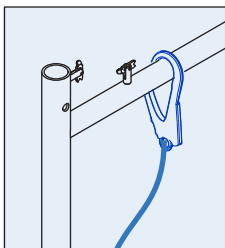

CAUTION: Do Not Climb Outside the Tower

For safety and structural stability, strictly avoid climbing the exterior of the tower. Opt for the designated interior route only, as deviations may jeopardize your safety and the tower's stability.

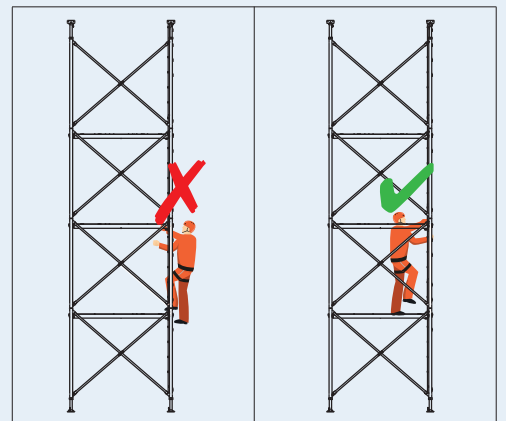

3- Versatile Adaptation for Optimal Construction Efficiency

Distinguished by its exceptional adaptability, the Scafframe system impeccably adjusts to many construction variables, including diverse ground plans, various heights, varied floor configurations, and its substantial load bearing capacity.

This adaptability positions it as an invaluable choice across a wide spectrum of construction scenarios. A key feature is the inclusion of various sizes of diagonal braces meticulously tailored to each frame height. This deliberate customization empowers builders to strategically space frames, allowing for precise adjustments. Frames can be positioned either closely or distantly based on the specific load requirements of the project.

Scafframe optimizes material usage, ensuring resource efficiency and sustainability. This unique combination makes it a preferred and cost-effective solution for a diverse range of construction projects.

Light loads - frames spaced further apart

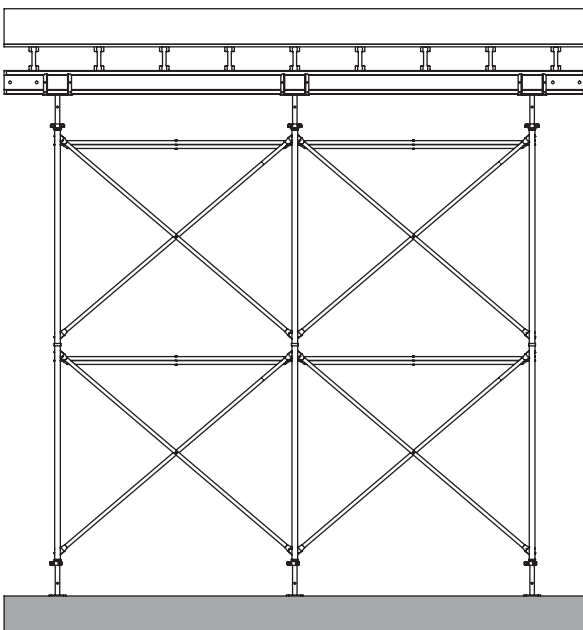

Heavy loads - frames spaced close together

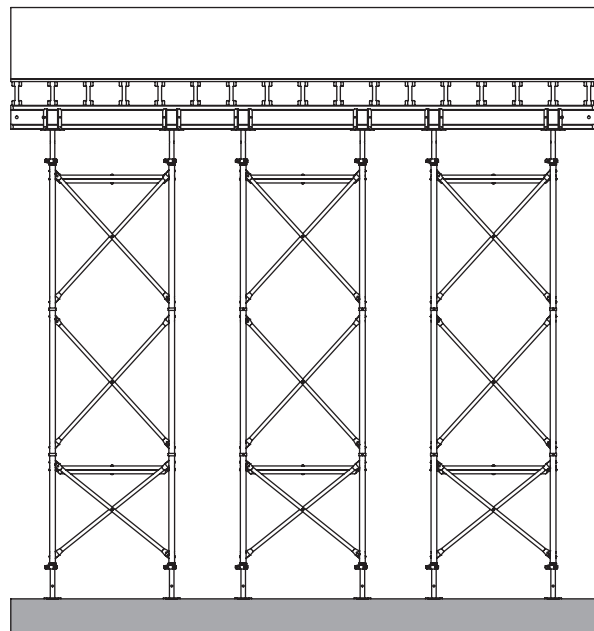

Plan view

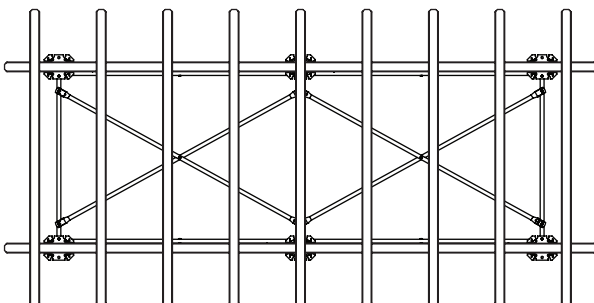

Plan view

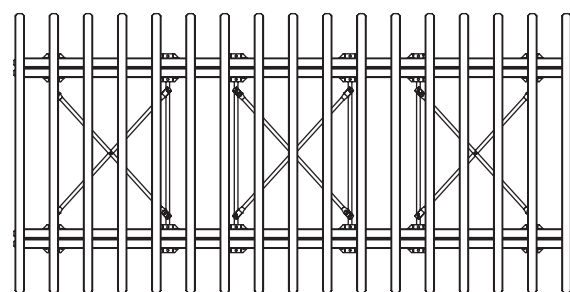

4- Height adjustment

The scafframe system offers versatile height adjustments with three distinct frame heights of 0.90m, 1.20m, and 1.80m, allowing for coarse adjustments within a 30cm range. For precision down to the last millimeter, fine adjustments are facilitated through a range of specialized head and base units. This comprehensive design ensures flexibility and meticulous control over the various heights in the construction industry.

Head zone

- 1- Adjustable U-Head
- 2- Adjustable 4-way Head
- 3- Adjustable U-Head 70 (Special)

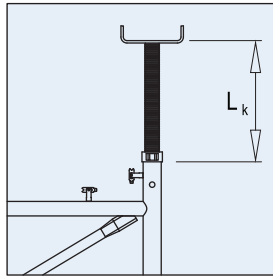

Frames in the top storey
1.8m/1.2m/0.9m 1.8m/1.2m 0.9m

	1	2	3	3	3
L _k max. (cm)	50	50	70	70	70
L _k min. (cm)	7	7	7	7	28

The minimum values indicated above do not involve a formwork-striking lowering distance.

To assemble the adjustable jacks in the head zone and ensure their secure attachment to the frames, the following can be followed:

- Place the Adjustable U-heads into the frames using a consistent and standardized approach.
- Affix each Adjustable U-head firmly to the frame by securing it with a safety hook.

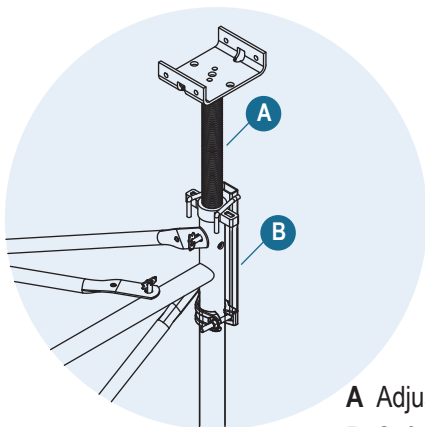

A Adjustable U-head
B Safety hook

Base zone

- 1- Adjustable Base Jack
- 2- Adjustable Base Jack (Special)

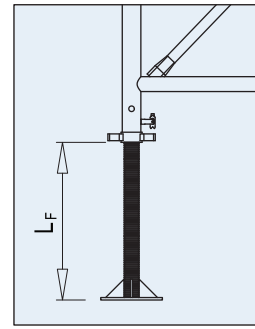

Frames in the top storey
1.8m/1.2m/0.9m 1.8m/1.2m 0.9m

	1	2	2	2
L _k max. (cm)	50	80	80	80
L _k min. (cm)	7	7	7	36

The minimum values indicated above do not involve a formwork-striking lowering distance.

To position the adjustable jacks in the base zone and ensure their stable attachment to the frames:

- Rotate the jack nut to achieve the preferred extended length for the base jack.
- Insert the base jack into position.
- Safely attach each base jack to the frame using a safety hook.

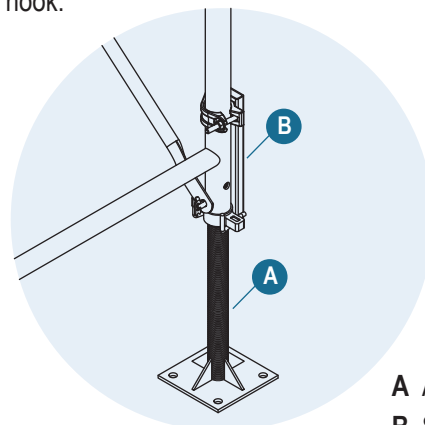

A Adjustable base jack
B Safety hook

By following these instructions, you can effectively assemble the head zone and base zone adjustable jacks, providing stability and safety through the secure connection of each adjustable jacks to the frames.

5- Assembly

Horizontal assembly of the Scafframe tower:

1- Preliminary Statement:

- The designations 'vertical' and 'horizontal,' particularly concerning the orientation of diagonal crosses, are consistently employed herein with respect to their eventual installation within the completed, upright tower.
- The commencement of the erection process for the load-bearing tower initiates from the base, denoted as the first 'storey.'

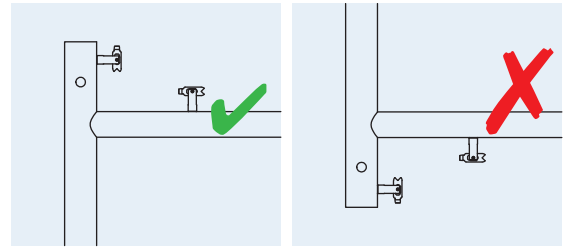

2- General Considerations:

- It is imperative that the gravity latches of the frame are consistently oriented in an upward direction.
- The process involves sliding the diagonal cross onto the safety-catch bolt and promptly securing it using the safety catch.

3- Erection of the Initial Storey:

- In accordance with the aforementioned instructions, the tower frames are positioned horizontally on timber supports of a suitable thickness ($\geq 4\text{cm}$).

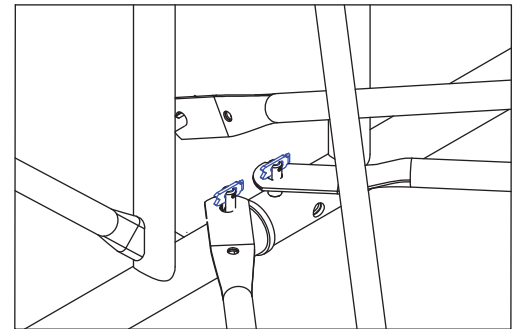

4- Vertical Bracing of the Frames (utilizing vertical diagonal crosses):

- The connection of frames is achieved through the implementation of diagonal crosses.

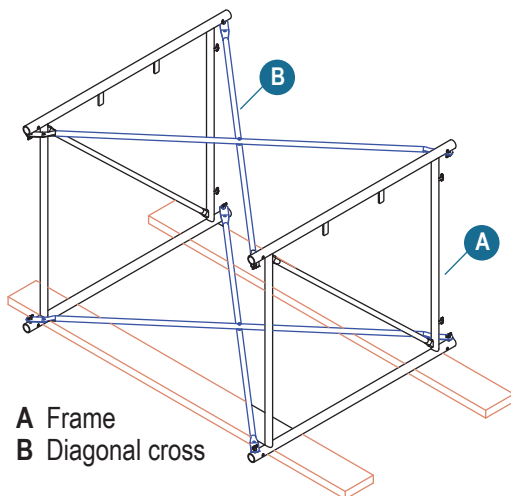

A Frame
B Diagonal cross

5- Horizontal Bracing of the Frames (utilizing horizontal diagonal crosses):

- Diagonal crosses are slotted onto the safety-catch bolts of the horizontal frame tubes and fixed securely in place.
- Base units are inserted and secured with safety hooks.

6- Fundamental Principle of Horizontal Crosses:

- Ensure geometric stability through the utilization of horizontal diagonal crosses in the first and second-last or last storey, or at intervals of 10m.
- Horizontal crosses are employed as needed, particularly in cases of horizontal restraint for the tower (even if temporary) and when local loads necessitate transfer (such as those incurred during the attachment of the tower to the crane after ground assembly in the horizontal).

- In instances where a solitary individual is assembling the tower, it is recommended to install the horizontal diagonal cross at the outset.

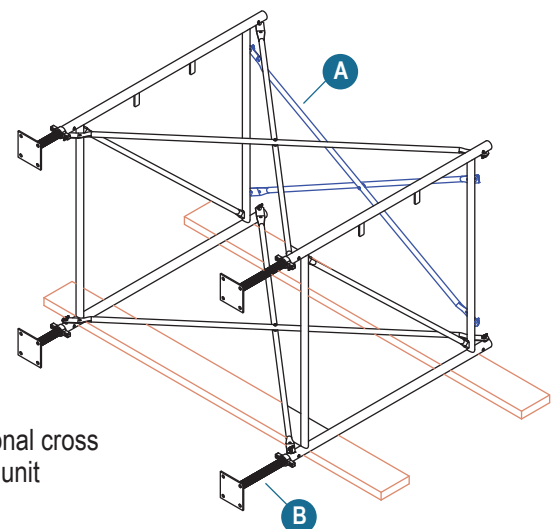
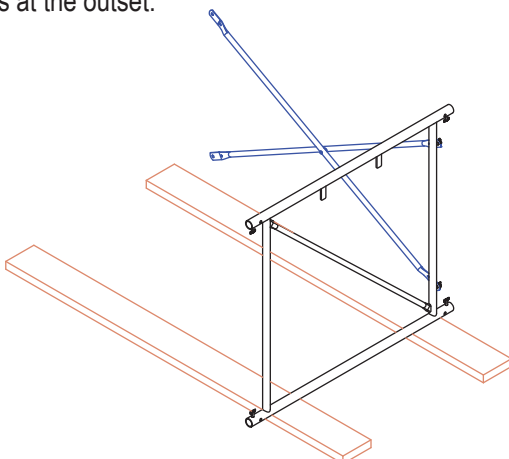

A Diagonal cross
B Base unit

7- Erection of Subsequent Storeys:

- Insert the Spigot connector into the frames to be added.
- Add the next frame and connect it to the frame below using 16mm Spring-locked connecting pins.
- Install and secure diagonal crosses in a manner similar to the first 'storey.'
- Insert head units and secure them with safety hooks.
- Install scaffold planking units where required.

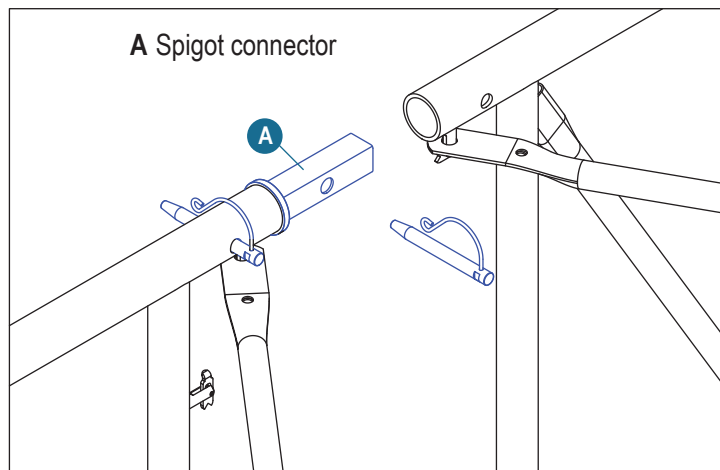

Do not pre-assemble units
any higher than 10m.

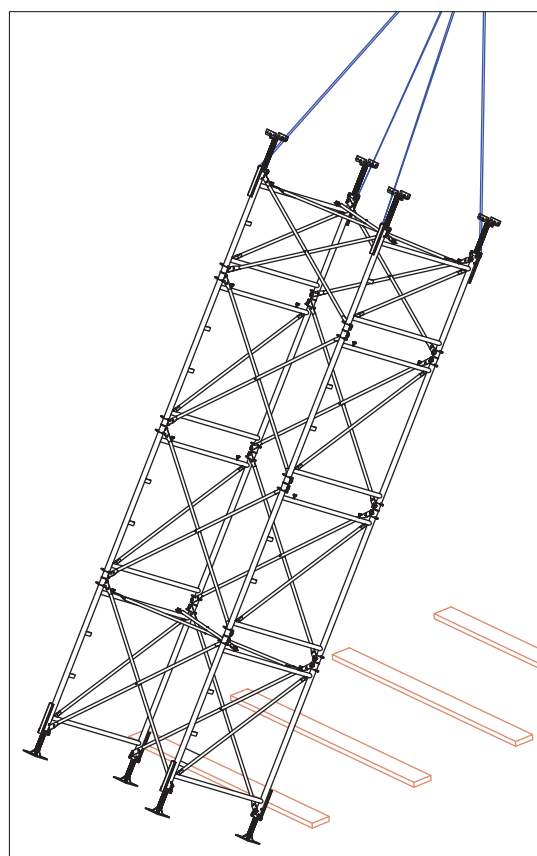
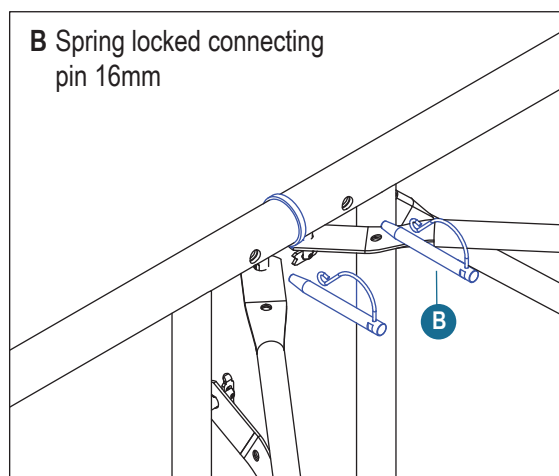
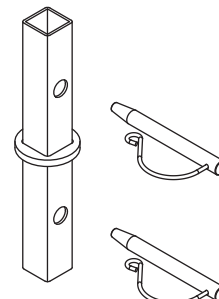

8- Uprighting Procedure with Crane Assistance:

Prior to attaching the crane suspension tackle, conduct the following checks:

- Ensure that all spring-locked connecting pins have been properly fitted to link the frames.
- Confirm that all safety catches are securely closed.
- Utilize safety hooks to secure all jacks, (head and base units), preventing any risk of drop-out.
- Erect the load-bearing tower in a vertical position on ground that possesses static load-bearing capabilities.
- For load-bearing towers exceeding a height of 6m, implement back-staying or connection with other towers.
- Attach the lifting chain to the frames of the top "storey" and lift the entire tower into an upright position.
- Upon the tower standing upright, recheck to ensure the closure of all safety catches.

Max. extension length of the base units when
the tower is being lifted into the upright: 35cm!

9- Disconnecting the lifting chain at ground level:

Required materials:

- 3 Scaffolding tubes size 48.3mm (T), with a minimum length equal to the inter-frame space(m) + 1.00m.
- 6 Double or swivel couplers size 48mm (C).
- Secure the scaffold tubes as outlined below:
 - One tube between the bottom frames.
 - Two tubes between the top frames.
- Fasten two cables, chains, or lifting straps to the bottom scaffold tube.
- Guide the cables, chains, or lifting straps along the exterior of the tower and through the space between the top scaffold tubes.
- Once the tower is raised into the upright position, a crew member at ground level should detach the cables, chains, or lifting straps.

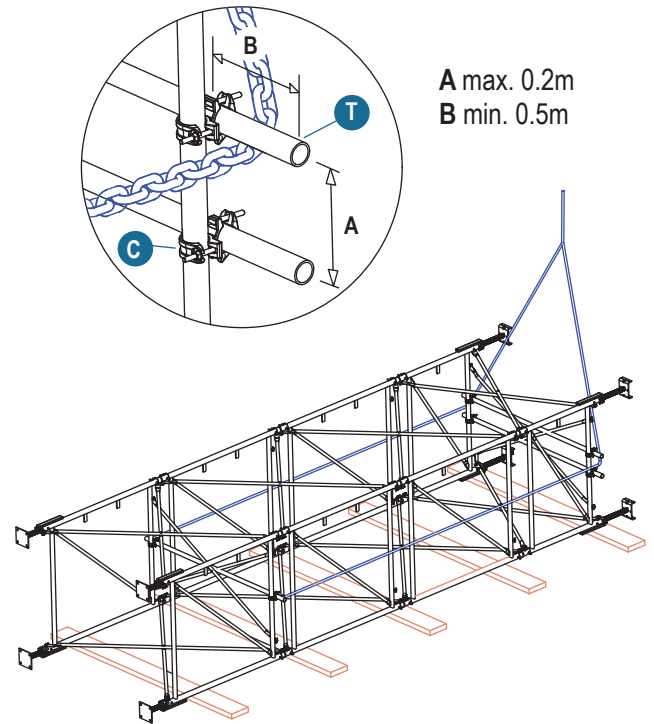

A max. 0.2m
B min. 0.5m

Caution: Do not employ this technique to reposition the tower on its side.

10- Dismantling:

- Once the tower is returned to a horizontal position, it can be disassembled by following the reverse order.
- During the planning phase, it's essential to consider dismantling operations, such as transporting or towing the load-bearing tower into the crane's reach for secure repositioning or horizontal on-ground dismantling.

Assembling towers in an upright position manually:

1- General:

- Assemble the load-bearing tower vertically on ground that can support the load.
- If the load-bearing tower exceeds a height of 6m, use braces or connect it with other towers.
- Place the diagonal cross onto the safety-catch bolt and promptly secure it with the safety catch.

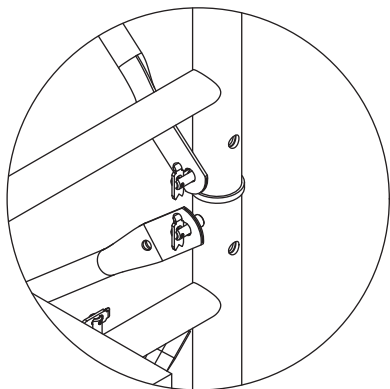

2- Assemble the first storey:

- Insert base units and secure it with safety hooks.

- Install and secure the diagonal crosses.

- Link the frames by connecting them with diagonal cross.

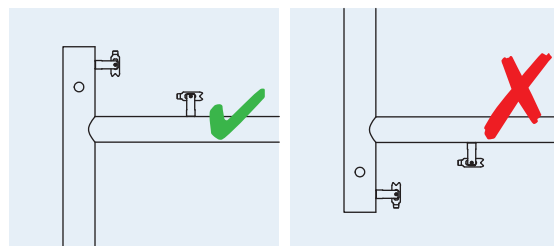

The frame's gravity latches should consistently point upward.

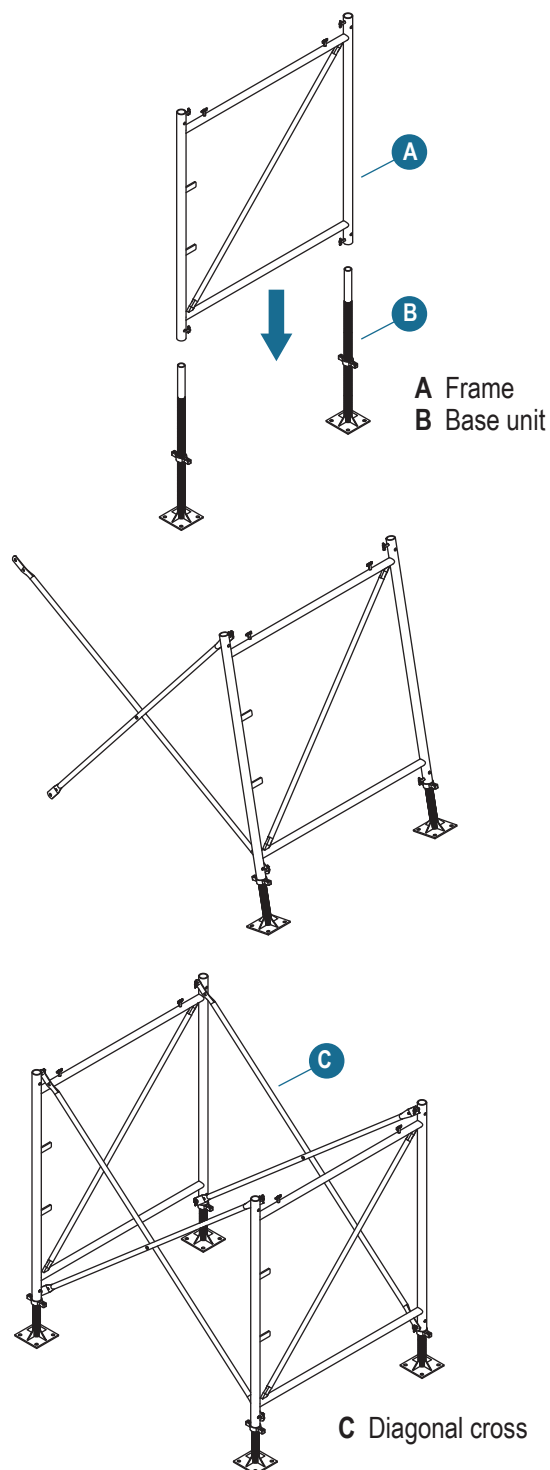

3- Constructing the second storey by stacking frames:

- Lay scaffold planking on the completed 'storey'.
- Install the spigot connector.
- Assemble the subsequent frames.

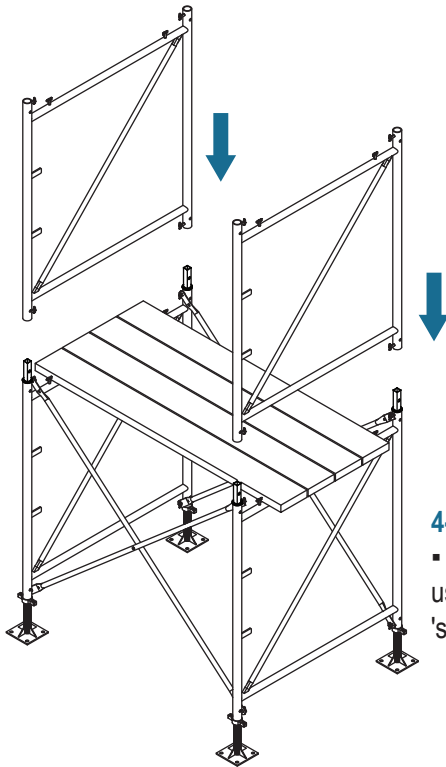

Note:

When the tower is scheduled for crane lifting, it is imperative to fasten the frames together using 16mm Spring-locked connecting pins to prevent any separation. Refer also to the 'Lifting by Crane' section for additional guidance.

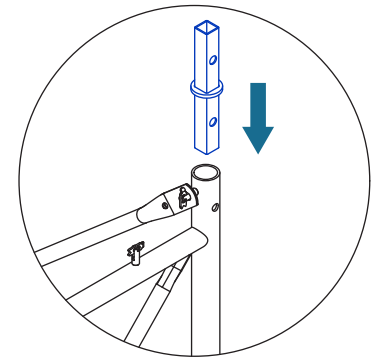

4- Bracing the frames vertically:

- Install and secure diagonal crosses using the same method as in the first 'storey'.

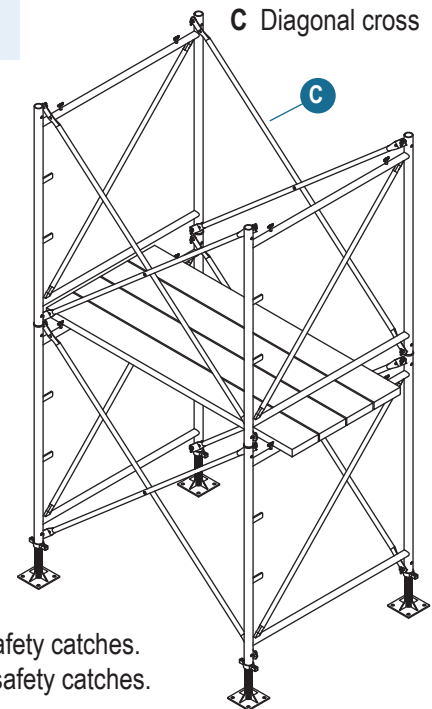

5- Constructing the third 'storey':

- Elevate the scaffold planking units to the subsequent level.
- Introduce 1.20m frames using the same method adopted for the second storey.
- Slide diagonal crosses onto the lower safety-catch bolts and fasten them with the safety catches.
- Slide diagonal crosses onto the upper safety-catch bolts and secure them with the safety catches.

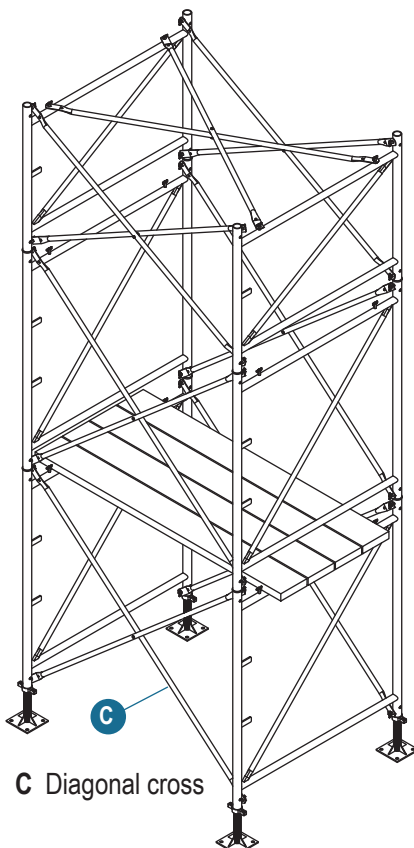

6- Horizontal Bracing of the Frames (utilizing horizontal diagonal crosses):

- Securing the geometry by means of **horizontal** diagonal cross in the 1st and second-last or last storey, or every 10m.
- Additionally as necessary, e.g.
 - if there is a horizontal restraint for the tower (even a temporary one).
 - if local loads need to be transferred (e.g. from attaching the tower to the crane after it has been ground-assembled horizontally).

7- Erecting further storeys:

- Introduce additional frames using the same method as employed for the third storey, and vertically brace them with diagonal crosses.
- For load-bearing towers exceeding 6m in height, provide backstays or integrate them with other towers.

8- Dismantling:

- Once the tower is returned to a horizontal position, it can be disassembled by following the reverse order.
- During the planning phase, it's essential to consider dismantling operations, such as transporting or towing the load-bearing tower into the crane's reach for secure repositioning or horizontal on-ground dismantling.

6- Lifting by crane

1- Lifting chain connected to the frame:

- Verify that the maximum tower weight for repositioning is 1200kg.
- Ensure the maximum tower height for lifting it into the upright position and placing it on its side is 10m.

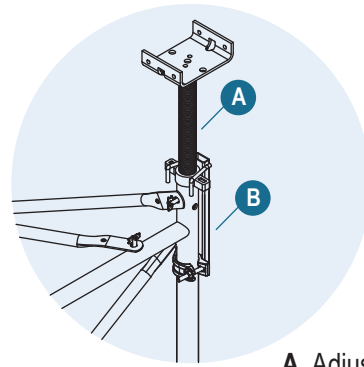

A Adjustable U-head
B Safety hook

2- Secure the head units:

- Prevent the head units from being lifted out by securing each adjustable U-head to the frame with a safety hook.

3- Secure the base units:

- Prevent the base units from dropping out by securing each Adjustable base jack to the frame using a safety hook

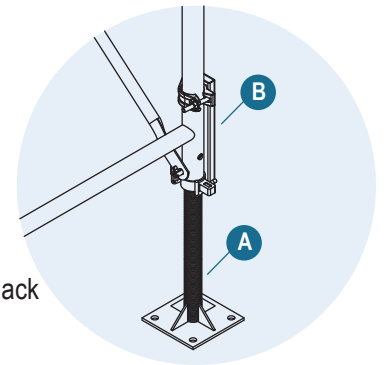

A Adjustable base jack
B Safety hook

4- Connect the frames securely for crane handling:

- Ensure the frames are secured with 16mm spring-locked connecting pins at each leg joint to prevent any pulling apart.

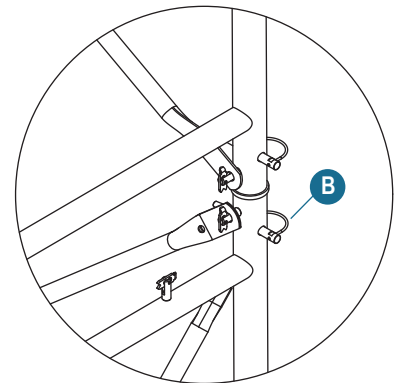

B Spring locked connecting pin 16mm

5- Repositioning procedure:

- Take off the formwork sheeting from the superstructure to enable the attachment of the lifting chain.
- Fasten the lifting chain solely to the frame nodes; avoid attempting to connect the lifting chain to the diagonal crosses.

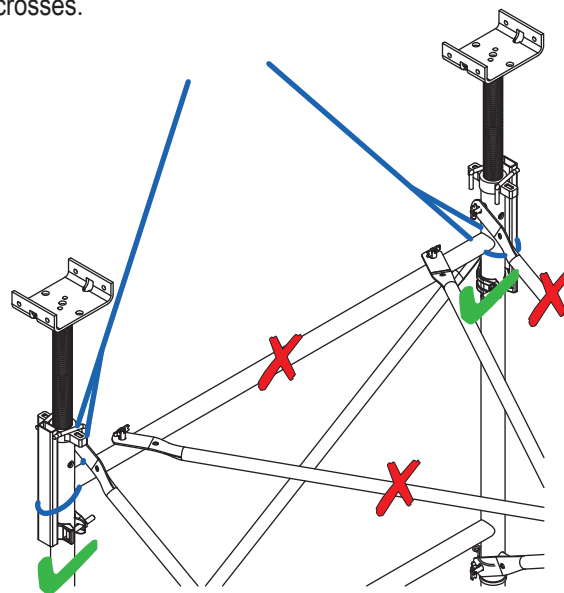

6- Lifting chain attachment to the superstructure:

- When repositioning the table formwork vertically, specifically for crane lifting, they must be equipped with a Lifting rod and relevant accessories. These components facilitate the easy attachment of transfer cables. Note that the maximum load-bearing capacity is 1000kg per Lifting rod when the load is centrally applied.
- Install the Lifting rod and other relevant accessories. Utilize a Ø 20mm drill bit to create a hole through the system sheathing, which can later be filled with a plastic plug.
- Ensure the connection of superstructure components, such as linking primary and secondary beams and affixing the system sheathing.
- Connect the superstructure to the head units using a locking rod and other relevant accessories.

7- Anchoring on the structure

With Anchoring shoe or Anchor Plate

Allowable forces transmitted through the anchoring shoe and anchor plate:

- T (tensile force): 11.75 kN perpendicular to the wall
- S (shear force): 6.50 kN parallel to the wall

The stated values apply when attaching the anchoring shoe to the permanent structure using either an anchor cone or anchor bolts. However, it's important to note that the anchor plate can only be affixed using the anchor bolts option. For additional information, please consult a Scaffco engineer.

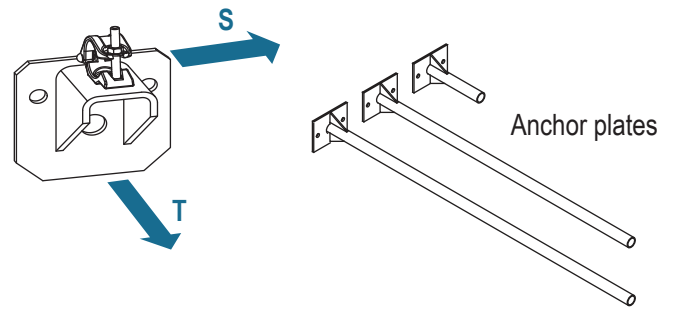

Anchoring Plane Design and Structural Stability:

In the structural configuration, the load-bearing tower intricately links to the Anchoring shoe through the utilization of scaffold tubes and couplers.

The determination of the vertical spacing between anchoring levels are contingent upon various factors, including the chosen assembly method, prevailing wind loads, the underlying design assumptions, and the specifics of frame-joints.

To augment structural robustness, it is imperative to incorporate a diagonal cross within the anchoring plane of the load-bearing tower. This addition serves as a crucial stiffening element, contributing to the overall stability of the structure. The precise design considerations for the anchoring planes, along with the maximum permissible distances from the structure, necessitate individual scrutiny and assessment tailored to the unique requirements of each project.

Furthermore, special attention is directed towards the bracing of adjacent load-bearing towers. This bracing is mandated by static requirements and should mirror the principles applied when towers are anchored directly to the supporting structure.

The systematic integration of bracing mechanisms between neighbouring load-bearing towers is vital for ensuring structural integrity and resilience, thereby aligning with the stringent demands of stability and safety.

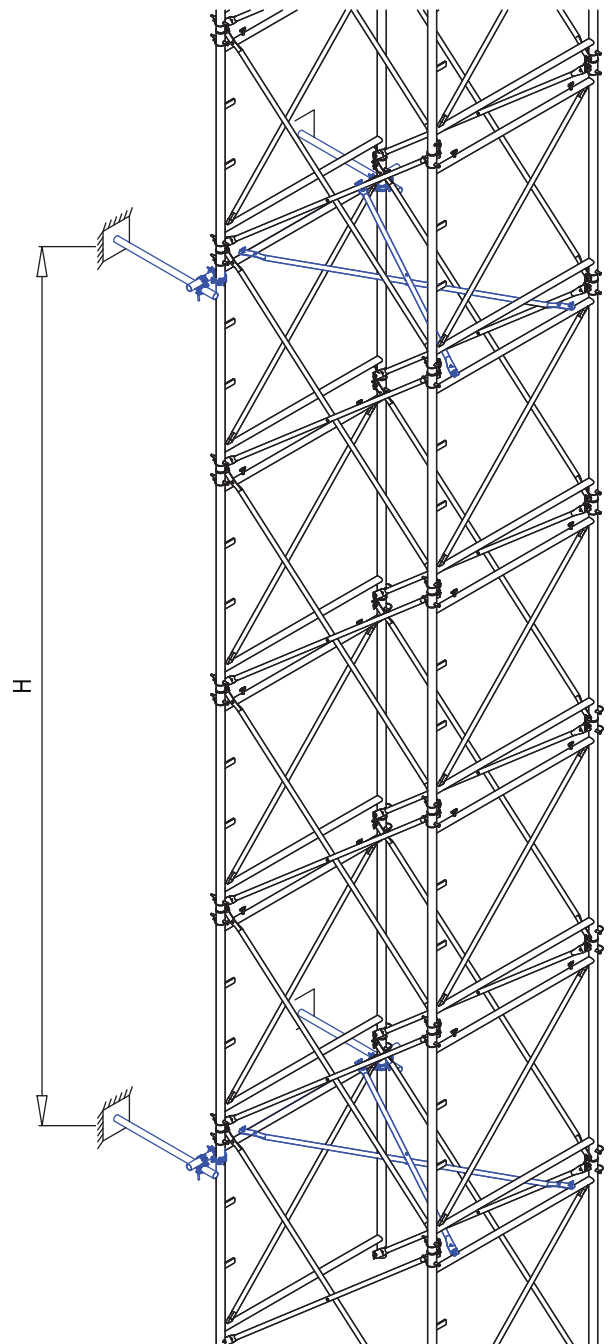

8- An intermediate level constructed using steel Wallings

Intermediate levels constructed with steel walings serve as one of the functions in facilitating the transfer of horizontal loads. The versatility of steel walings in this context is highlighted through various applications:

1. Connection of a Back-Stay:

One utilization of steel walings is the establishment of a connection for a back-stay. This involves integrating the steel walings strategically to provide additional support against horizontal forces. The connection of a back-stay becomes a pivotal element in enhancing the overall stability of the structure.

2. Support Against and /or Anchoring to the Structure:

Steel walings can be employed to provide support against or anchor the intermediate levels to the permanent works. This application involves securing the walings to the structure, effectively distributing and redirecting horizontal loads.

3. Formation of a Truss of Cross-Braced Horizontal Steel Walings:

Another noteworthy application is the formation of a truss using cross-braced horizontal steel walings. This entails arranging the steel walings in a truss-like configuration, introducing diagonal bracing to enhance the load-bearing capacity.

Each of these possibilities showcases the adaptability of steel walings in addressing horizontal load transfer requirements. The selection of a specific application depends on the structural design, load considerations, and project specifications. Incorporating steel walings in intermediate levels not only ensures the stability of the structure but also contributes to the overall stability of the load-bearing tower against varying horizontal forces.

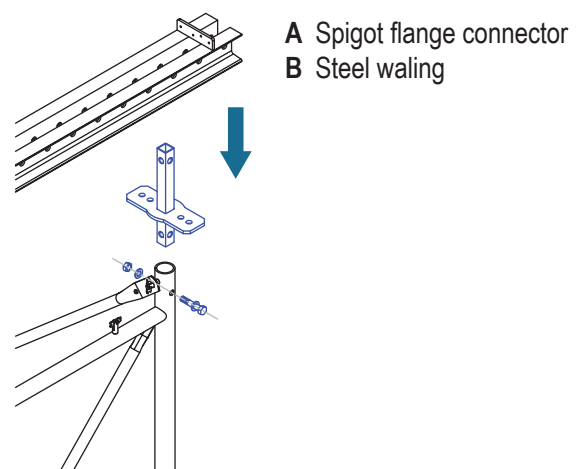
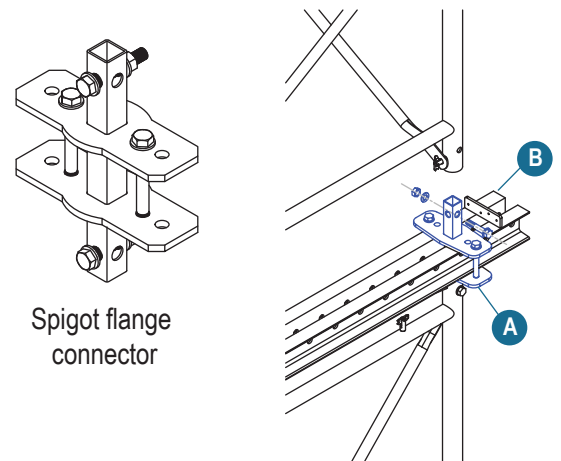

9- Temporary back-stays with tie rods for site Erection:

Implementing temporary back-stays with tie rods directly on the load-bearing tower is a specialized technique employed exclusively during the erection phase of the construction project. It is important to emphasize that this method is specifically designed for providing support and stability during the tower's assembly but is not intended for the transfer of planned horizontal loads in the operational phase of the structure.

Chains or cables present an alternative yet equally effective means for temporary back-staying during the erection of the load-bearing tower. This approach involves strategically incorporating flexible chains or cables to provide additional support and stability throughout the tower's assembly.

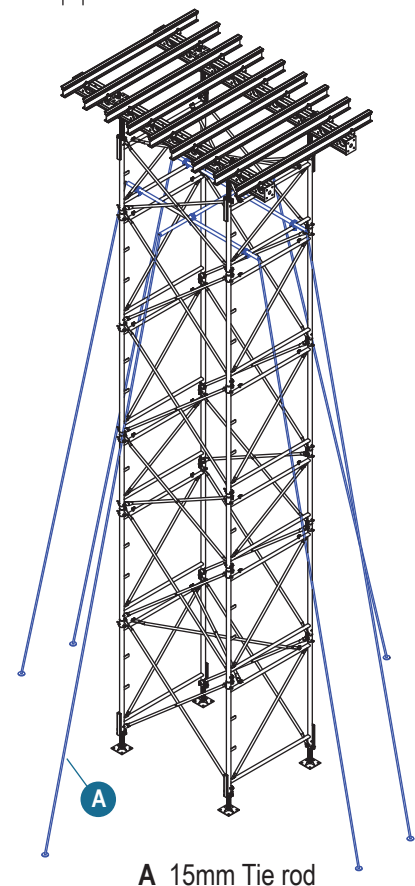

A 15mm Tie rod

10- Structural design

Usage Requirements:

- When dealing with multi-plane towers featuring varying inter-frame spaces, the design load is determined by the smallest inter-frame space.
- Proper securing of primary beams is essential to prevent overturning, akin to conventional applications involving primary and secondary beams.
- A qualified individual must furnish separate verification for the foundation, with special attention to the ground-bearing pressure.
- Intermediate anchoring planes might be necessary during the tower erection process.
- For technical information not provided or indicated, it is recommended to consult with a Scaffco engineer.

11- Permitted leg loads

Free-standing towers (without bracing, without holding device):

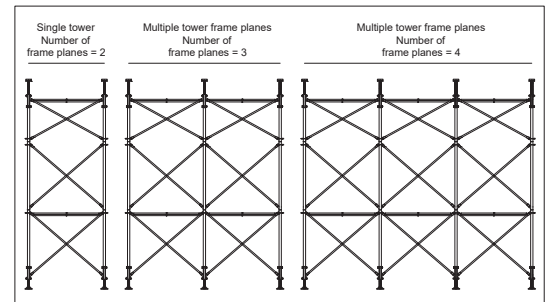
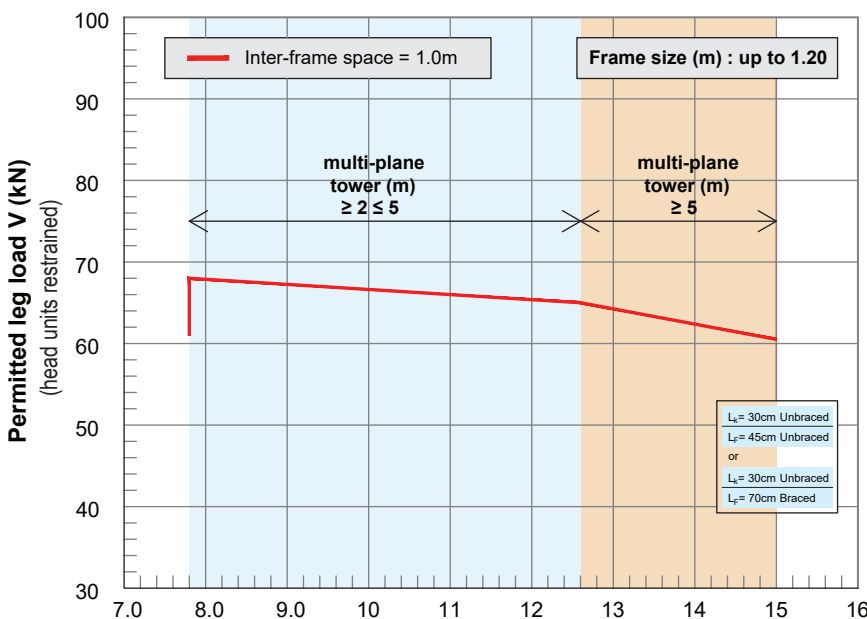
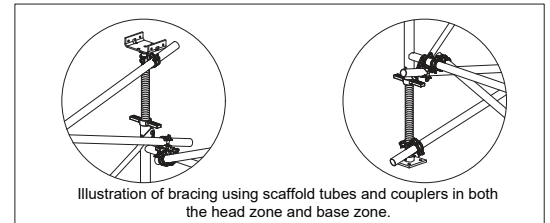
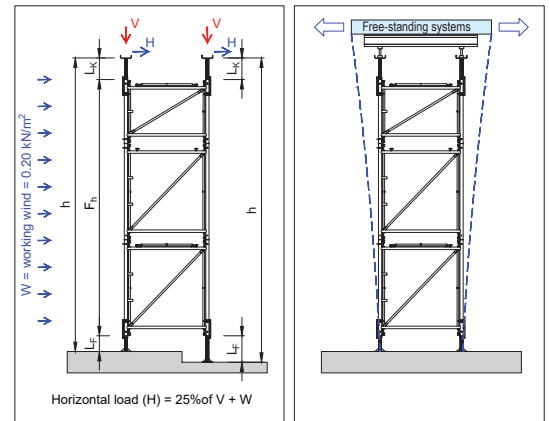
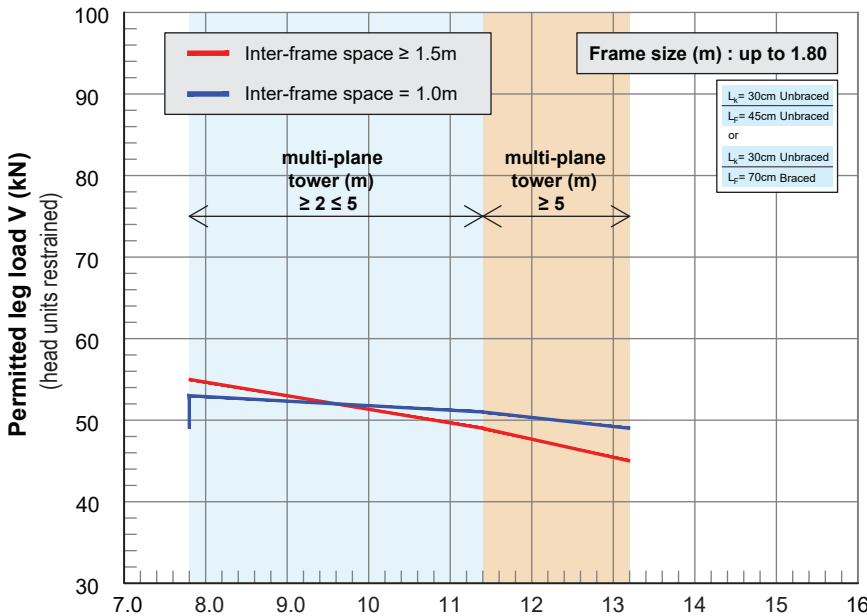

Top-held systems (enclosed space, or with bracing):

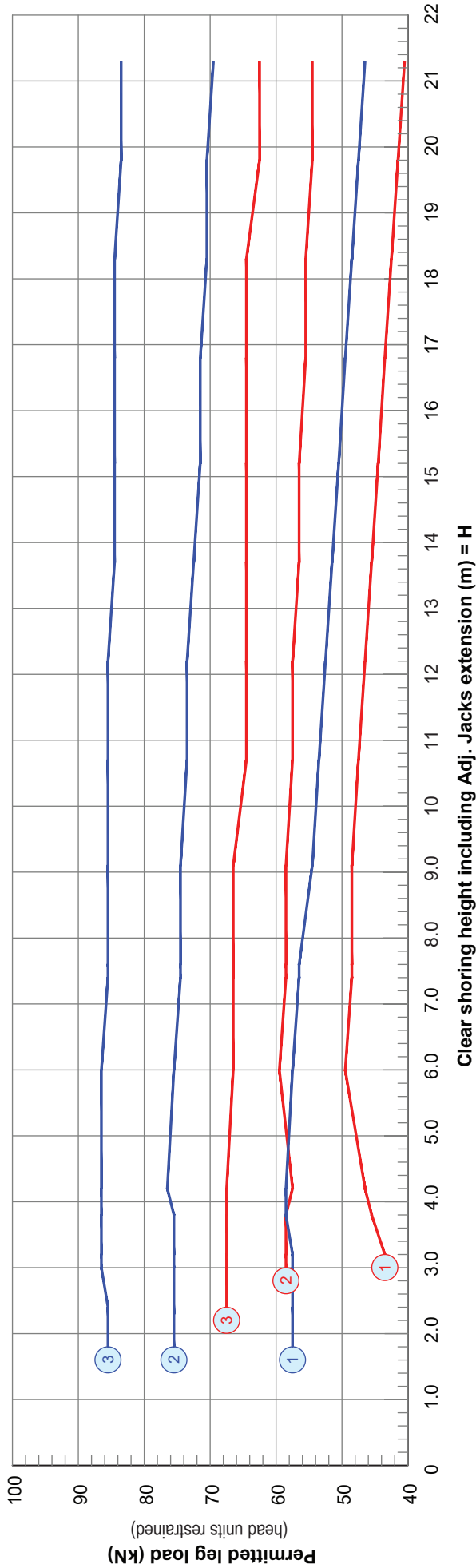

To securely transfer horizontal loads, it is essential to anchor the superstructure or slab formwork to existing permanent structural elements or, alternatively, employ external bracing.

This table is specifically designed for load-bearing towers with a minimum plan layout of 1.5 x 1.5 m. If a smaller plan layout is required (with diagonal crosses less than 1.5m), multi-plane towers must be utilized. For instance, when using a 100cm diagonal cross, a tower with 3 planes is recommended, and for a 60cm diagonal cross, a tower with 4 planes is advisable. Refer to the accompanying graphical representation for an illustration of multi-plane towers.

Scafframe tower with frames 0.90m, 1.20m or 1.80m	Curve (1)	L _k = 30cm Unbraced
	Curve (2)	L _k = 45cm Unbraced
	Curve (3)	L _k = 45cm Unbraced L _k = 70cm Braced L _k = 70cm Braced
Scafframe tower with frames 0.90m, 1.20m	Curve (1)	L _k = 30cm Unbraced
	Curve (2)	L _k = 45cm Unbraced
	Curve (3)	L _k = 45cm Unbraced L _k = 70cm Braced L _k = 70cm Braced

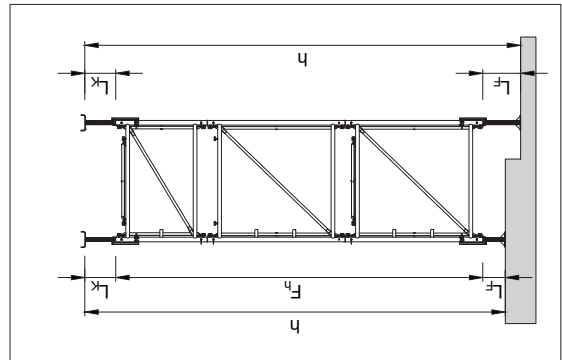
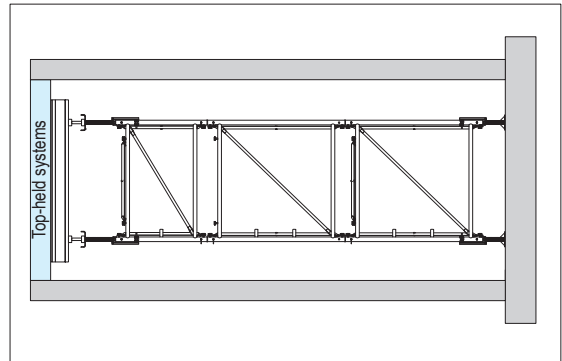
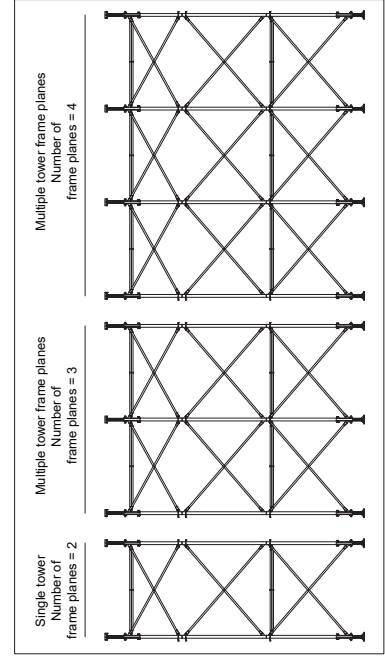

12- Main system components

	Wt. (kg)
Frame 0.90m	20.0
Frame 1.20m	24.7
Frame 1.80m	32.5

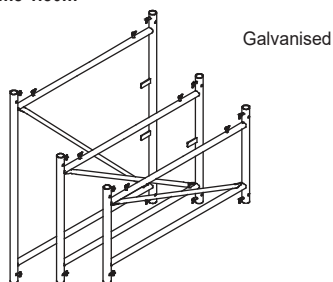

Spigot connector	1.09
------------------	------



Spring locked connecting pin 16mm	0.25
-----------------------------------	------

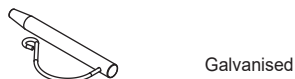

Diagonal cross 9.060	3.0
Diagonal cross 9.100	4.0
Diagonal cross 9.150	5.0
Diagonal cross 9.175	6.0
Diagonal cross 9.200	6.5
Diagonal cross 9.250	7.5
Diagonal cross 9.300	8.8
Diagonal cross 12.060	4.1
Diagonal cross 12.100	4.5
Diagonal cross 12.150	5.6
Diagonal cross 12.175	6.2
Diagonal cross 12.200	6.7
Diagonal cross 12.250	8.1
Diagonal cross 12.300	9.1
Diagonal cross 18.100	6.0
Diagonal cross 18.150	6.7
Diagonal cross 18.175	7.5
Diagonal cross 18.200	7.7
Diagonal cross 18.250	9.0
Diagonal cross 18.300	10.1

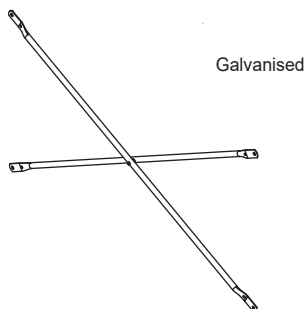

Adjustable 4-Way Head	9.0
-----------------------	-----

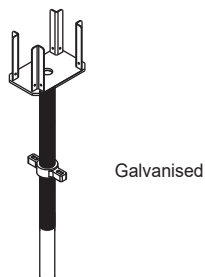

Code	Wt. (kg)	Code
------	----------	------

Adjustable U-Head	7.20
-------------------	------

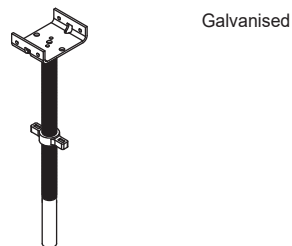

Safety hook	1.32
-------------	------



Anchor plate 15.0	1.1
-------------------	-----



Clamping plate	1.9
----------------	-----



Wing nut 15.0	0.31
---------------	------

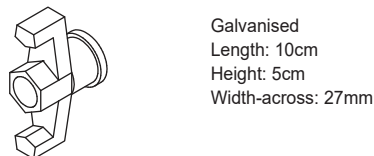

Locking rod	0.66
-------------	------



Adjustable base jack	7.14
----------------------	------

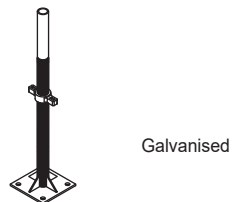

Adjustable base jack-80	9.2
-------------------------	-----

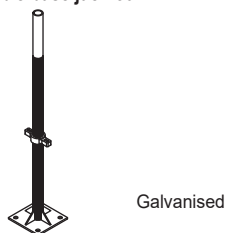

Wt. (kg) Code

Spigot flange connector W10

5.6

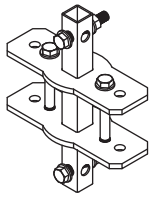

Galvanised

Anchoring shoe

3.6

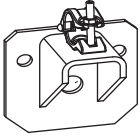

Galvanised

Anchor Plate

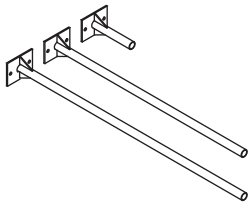

AP 030cm
AP 060cm
AP 150cm
AP 180cm

3.07
4.07
7.09
8.09

Aluminum Beam T225

Area 32.9 cm²
Weight kg/m 9.0
I_{xx} 2293 cm⁴
Z_{xx} 203.82 cm³
I_{yy} 289.4 cm⁴
Z_{yy} 57.88 cm³

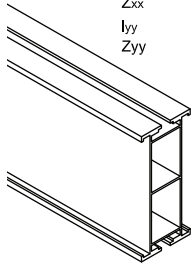

T225 - 7.20m 64.80
T225 - 6.00m 54.00
T225 - 5.40m 48.60
T225 - 5.15m 46.40
T225 - 4.80m 43.20
T225 - 4.20m 37.80
T225 - 3.60m 32.40
T225 - 3.00m 27.00
T225 - 2.40m 21.60
T225 - 1.80m 16.20
T225 - 1.20m 10.80
T225 -1.00m 9.00

H20 C-Clamp (Soldier to H20)

0.90

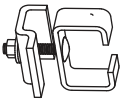

Galvanised

Soldier Clamp H20 (Soldier to H20)

0.80



Galvanised

Universal Clamp

0.60

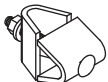

Galvanised

Angle Connector H20

0.33



Galvanised

Angle Connector (H20 - 40)

0.54



Galvanised

H20 Timber Beam

Wt. (kg)

Code

H20 Timber Beam 0125cm 6.25
H20 Timber Beam 0145cm 7.25
H20 Timber Beam 0165cm 8.25
H20 Timber Beam 0180cm 9.00
H20 Timber Beam 0225cm 11.25
H20 Timber Beam 0245cm 12.25
H20 Timber Beam 0265cm 13.25
H20 Timber Beam 0290cm 14.50
H20 Timber Beam 0295cm 14.75
H20 Timber Beam 0330cm 16.50
H20 Timber Beam 0360cm 18.00
H20 Timber Beam 0390cm 19.50
H20 Timber Beam 0450cm 22.50
H20 Timber Beam 0490cm 24.50
H20 Timber Beam 0590cm 29.50
H20 Timber Beam 1190cm 59.50

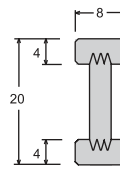
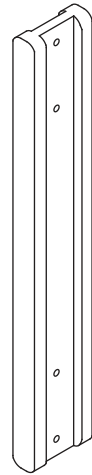

Moment: 5.00 kN.m
Shear: 11kN
Area: 18.87 cm²
E.I= 500 kNm

Finish: Varnished Yellow
Supports are rounded at the end for damage protection. Web-three layer crosswise laminated solid timber panel.
Weight: 5kg per running meter

Aluminum Beam S150

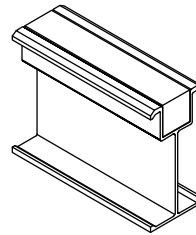

Finish: Mill Finish

Moment of resistance: 6.80kN.m
Area:11.96cm²
Inertia xx: 356cm⁴
Inertia yy: 43.764cm⁴
Section Modulus Z_{xx}: 47.15cm³
Young's Modulus: 69000N/mm²
Weight:3.95 kg/m(with Timber)
(Timber Wt.=0.75kg/m)

S150-050cm 1.95
S150-075cm 2.93
S150-100cm 3.90
S150-125cm 4.88
S150-150cm 5.85
S150-175cm 6.83
S150-200cm 7.80
S150-225cm 8.78
S150-250cm 9.75
S150-275cm 10.73
S150-300cm 11.70
S150-325cm 12.68
S150-350cm 13.65
S150-375cm 14.63
S150-400cm 15.60
S150-425cm 16.58
S150-450cm 17.55
S150-475cm 18.53
S150-500cm 19.50
S150-525cm 20.48
S150-550cm 21.45
S150-575cm 22.43
S150-600cm 23.40

Aluminum Beam T150

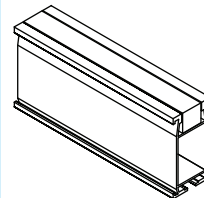

Finish: Mill Finish

Moment of resistance: 13.00kN.m
Area:18.87cm²
Inertia xx: 574.3cm⁴
Inertia yy: 147.4cm⁴
Section modulus Z_{xx}: 75.36cm³
Young's Modulus 69000N/mm²
Weight: 5.80kg/m (with Timber)
Timber Wt.=0.75kg/m

T150-050cm 2.93
T150-075cm 4.39
T150-100cm 5.85
T150-125cm 7.31
T150-150cm 8.78
T150-175cm 10.24
T150-200cm 11.70
T150-225cm 13.16
T150-250cm 14.63
T150-275cm 16.09
T150-300cm 17.55
T150-325cm 19.01
T150-350cm 20.48
T150-375cm 21.94
T150-400cm 23.40
T150-425cm 24.86
T150-450cm 26.33
T150-475cm 27.79
T150-500cm 29.25
T150-525cm 30.71
T150-550cm 32.18
T150-575cm 33.64
T150-600cm 35.10

Phone:

+971 4 886 2855

Email Us:

sales@scaffco.com

Address:

P.O. BOX 18234 Jebel Ali Dubai – UAE

Phone:

+971 2 550 0688

Email Us:

sales@scaffco.com

Address:

PO. BOX 41851- Abu Dhabi – UAE