

S- MAX PANEL **FORMWORK SYSTEM**

The Ultimate Panel Formwork System for All
Construction Site Needs

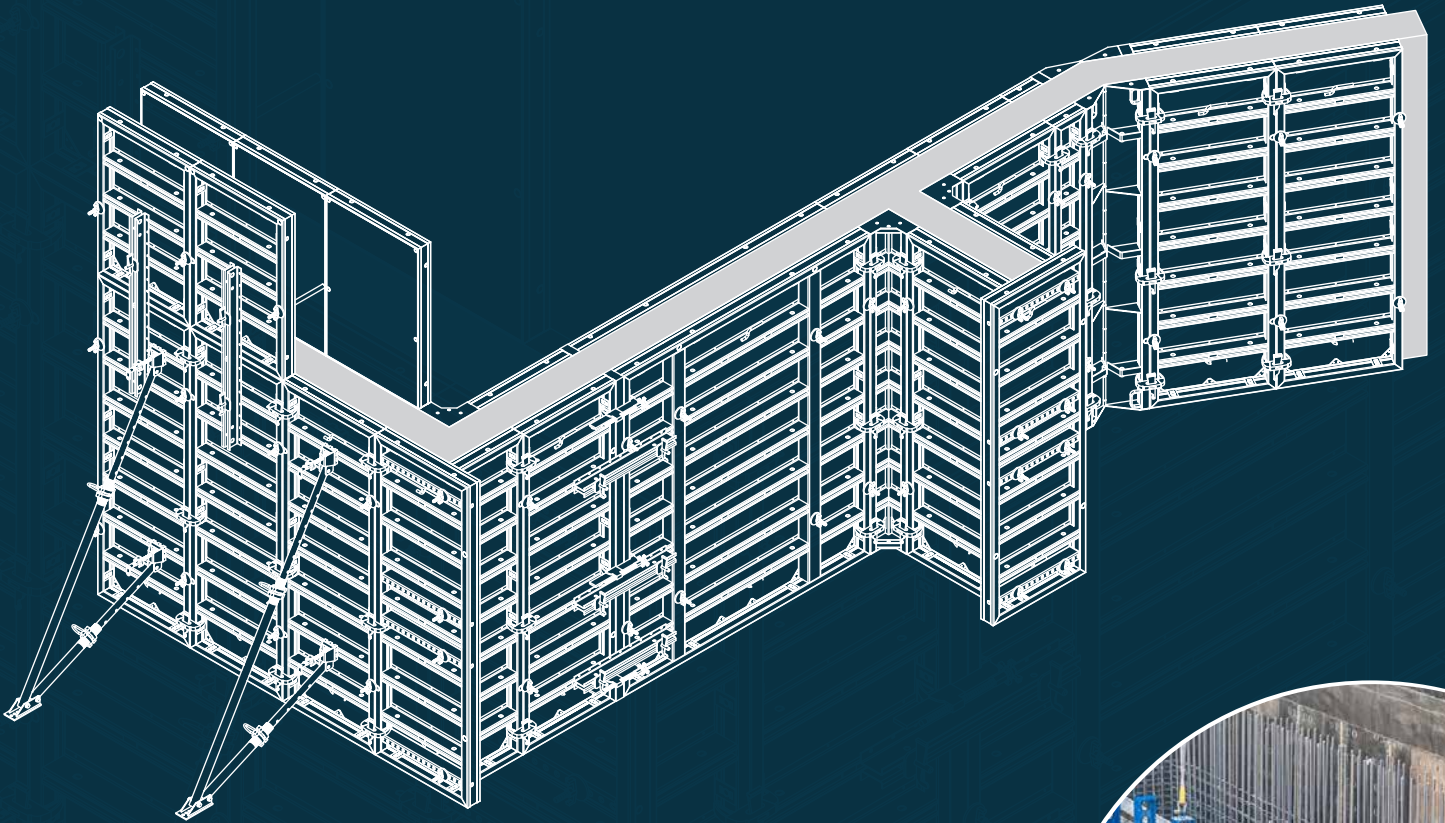



Disclaimer:

While every effort has been made to ensure the accuracy of the information in this catalogue, we cannot accept responsibility for any errors which may occur as a result of reliance on the contents of this catalogue and are not liable for any loss of any nature that may be incurred as a result of such reliance. Details of any of the products may change without prior notice.

The customer must ensure that 'good practice' is adopted on site by competent persons and that the products shown in this catalogue are erected, used and stripped in accordance with the relevant Codes of Practice, international standards and the local authorities regulations. This catalogue does not contain any design detail but lists and depicts the items available under this product range. The responsibility for design is the responsibility of the customer. Please, contact Scaffco's engineer for any technical inquiries.

تنويه:

في حين تم بذل كل جهد ممكن لضمان دقة المعلومات الواردة في هذا الدليل، لا يمكن أن تقبل شركة سكايفكو المسؤولية عن أي أخطاء قد تحدث نتيجة الاعتماد على أي من محتويات هذا الدليل، والشركة غير مسؤولة عن أي خسارة من أي نوع قد يتم تكبدها نتيجة لأعتماد محتويات هذا الدليل. تحتفظ الشركة بحق تغيير أي من المنتجات أو التفاصيل دون إشعار مسبق.

يجب على العملاء التأكد من أن يتم تبني الممارسات الصحيحة في الموقع من ناحية استخدام المعدات المذكورة في هذا الدليل. كذلك يجب على العملاء التأكد من كفاءة وحرفية الأشخاص القائمين على تركيب واستعمال وتفكيك عناصر الأنظمة وأن تكون هذه العمليات متطابقة مع المتطلبات والمعايير المذكورة في المواصفات الدولية ذات العلاقة ولوائح وتعليمات السلطات المحلية. هذا الدليل لا يحتوي على أية تفاصيل تخص التصميم ولكن يصف مكونات الأنظمة بشكل تصويري ويعطي فكرة عن عناصر الأنظمة المتاحة في إطار هذه المجموعة من المنتجات. الرجاء الاتصال بمهندس شركة سكايفكو للحصول على أي استفسارات فنية تخص المنتجات المذكورة في هذا الدليل.



SCAFFCO

Formwork & Scaffolding

SCAFFCO has a proven history of over 40 years in designing, manufacturing, and supplying scaffolding and formwork solutions for the Construction, Infrastructure, O&G and Industrial sectors.

Established in 1980, as an agent of leading brands of scaffolding and formwork products, SCAFFCO has rapidly grown to become a recognized manufacturer and solution provider for scaffolding and formwork systems with an established local and export network covering the GCC, Africa, and Europe.

Our unique value proposition model is driven by superior safety & quality standards, versatile systems, operational excellence and value engineering. All dedicated to address customer specific needs.

Today our manufacturing operations are based in two facilities located JAFZA – Dubai & Mussafah ICAD1 – Abu Dhabi and extend over an area of more than 50,000 Square meters. Our manufacturing facilities are equipped with automated robotic production units and embrace a robust and comprehensive quality system and process controls. The company has a production capacity that exceeds 50,000 tons of products annually.

In addition to our leading manufacturing capabilities, we have established a proven track record of expertise offering solutions from design, manufacturing, pre-assembly up to installation, training, supervision and inspection services on site. Our executed projects reference list includes a large selection of prestigious and landmark projects.

Mission Statement

At SCAFFCO, we are dedicated to creating value for our customers by providing optimized and efficient Scaffolding and Formwork solutions in accordance with the highest international safety and quality standards.

Vision Statement

Our vision is to set global benchmarks in scaffolding and formwork, pioneering innovation, safety, and quality in construction. We aim to redefine industry standards, pushing boundaries with relentless commitment to excellence.

The Ultimate Panel Formwork System for All Construction Site Needs

S-Max panel formwork is the complete solution that perfectly caters to your requirements on any construction site. With its exceptional safety features and practical working accessories, it offers a swift and cost-effective solution for formwork projects, particularly those involving large areas.

The innovative panel-size grid, featuring five different widths and three different heights of panels, including an extra-large option, ensures unparalleled adaptability to suit all construction-site situations. Whether you're working on expansive walls, columns, circular formwork, or foundations, S-Max is the ideal choice.



Max. Concrete
Pressure
80 kN/m²

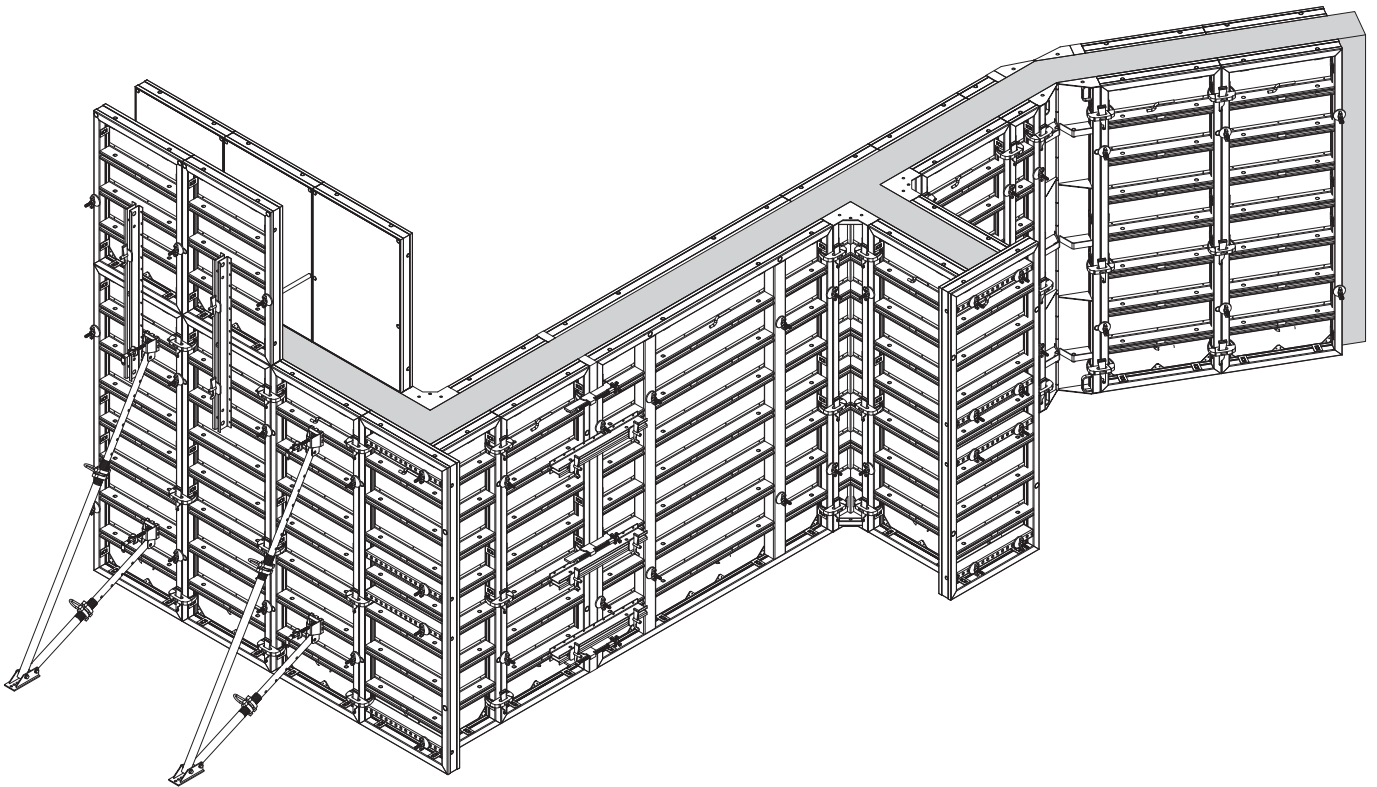

S-Max panel formwork is a comprehensive system equipped with excellent safety features and workplace accessories. This system provides everything you need to efficiently and swiftly tackle your forming tasks. By employing a minimal variety of panel sizes, the system achieves a consistent 15cm increment grid. The connecting devices and accessories are specifically designed to align with this grid, ensuring seamless integration. The quality plywood sheets are built to endure intensive re-use, consistently delivering exceptional concrete results.

The high-performance formwork designed for forming a variety of vertical concrete elements

The versatility of S-Max panel formwork makes it an ideal choice for various applications, including large-area walls, columns, circular formwork, and foundations. With a range of practical accessories, the system streamlines on-site work, eliminating the need for expensive improvisations. Furthermore, S-Max panel formwork seamlessly integrates with the S-Max Aluminium framed formwork. Both systems utilize interchangeable linking parts and accessories, providing utmost compatibility.

With the steel version of the system, you can efficiently form extensive areas using crane-shifted gangs. Subsequently, you can seamlessly transition to forming manually with aluminium frames, without the need to wait for the crane.

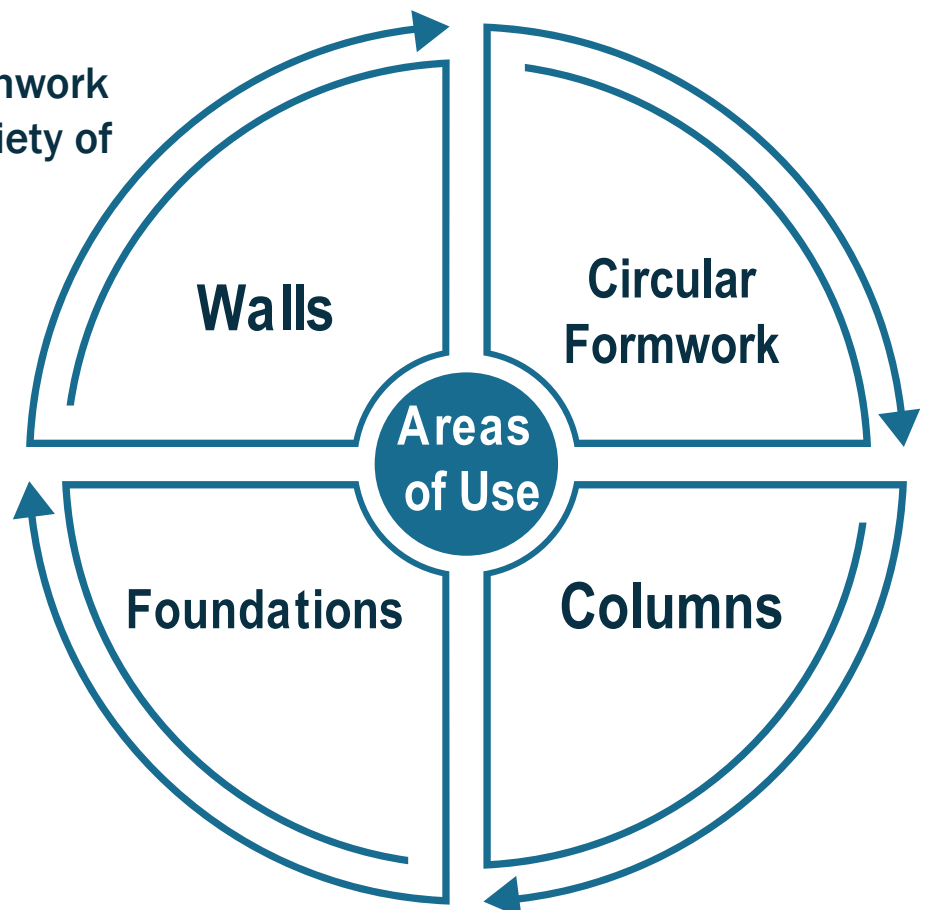

The logical system grid

S-Max Standard panels: Panel widths and heights

The combination of heights and widths in the S-Max panels create a practical and beneficial grid system, enhancing the formwork's adaptability and cost effectiveness. You only require 5 different widths and 3 varying heights of panels, including 2 extra-large panels, to effectively accommodate any architectural layout. Adjustments in height and width can be easily achieved through 15cm increments, adding to the convenience of the system.

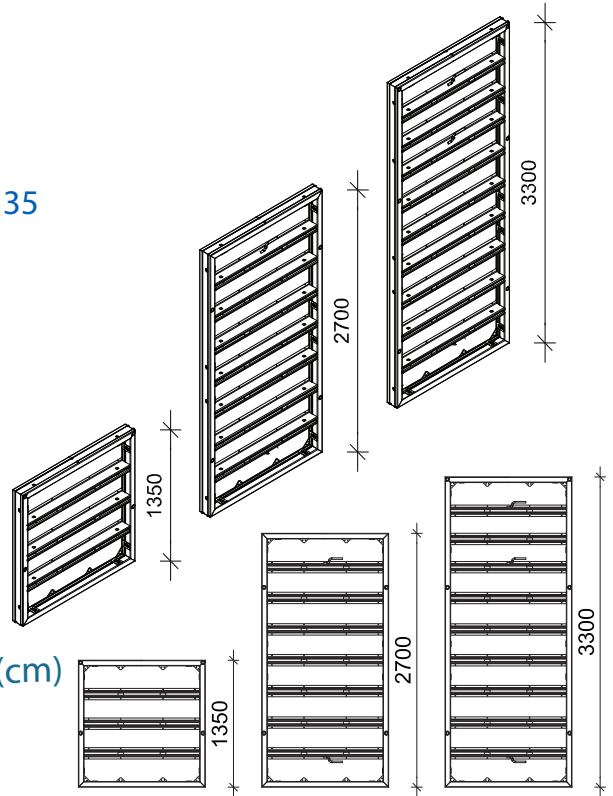
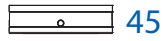
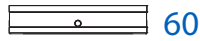
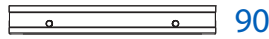
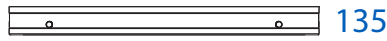

S-Max Large Area panels: Panel widths and heights (cm)

S-Max large panel for large-area formwork units.

Integrates two heights and two widths :

When upright - height 2.70m, width 2.40m & height 3.30m, width 2.40m

When on side - height 2.40m, width 2.70m & height 2.40m, width 3.30m

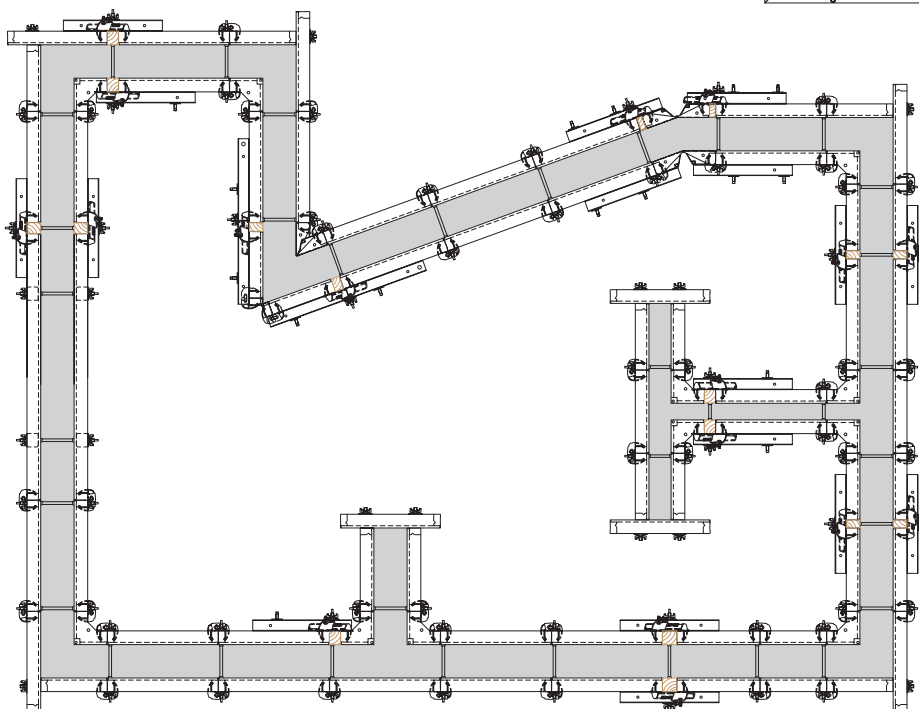
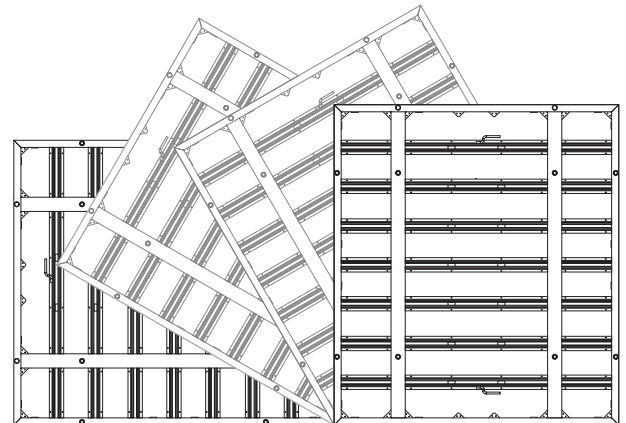
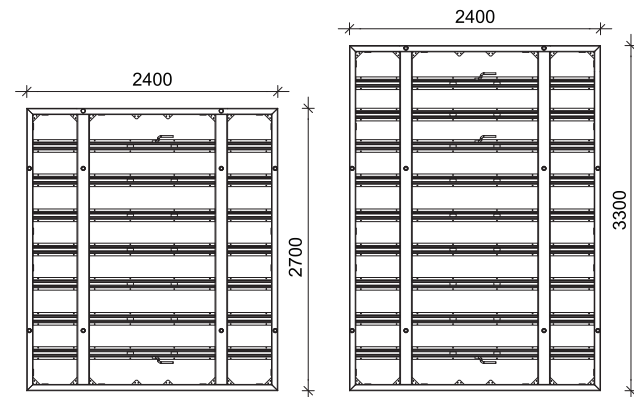
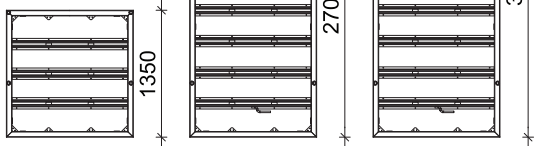

A variety of panel dimensions, coupled with a full range of accessories, ensure versatile usage on construction site.

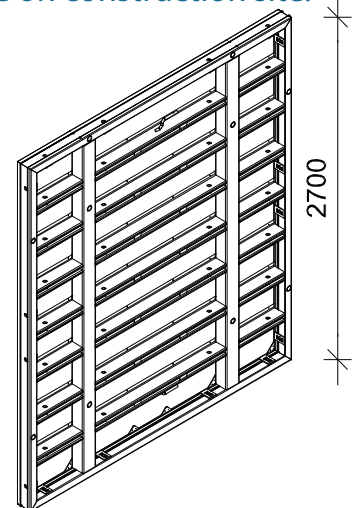

S-Max Panel Families

To meet the specific demands of construction sites, we can tailor and customize panel sizes as needed. This flexibility ensures that any required panel size can be manufactured to address the unique requirements of construction projects. Whether larger or smaller panels are necessary, our production capabilities are adaptable to provide the ideal solutions for construction site specifications.

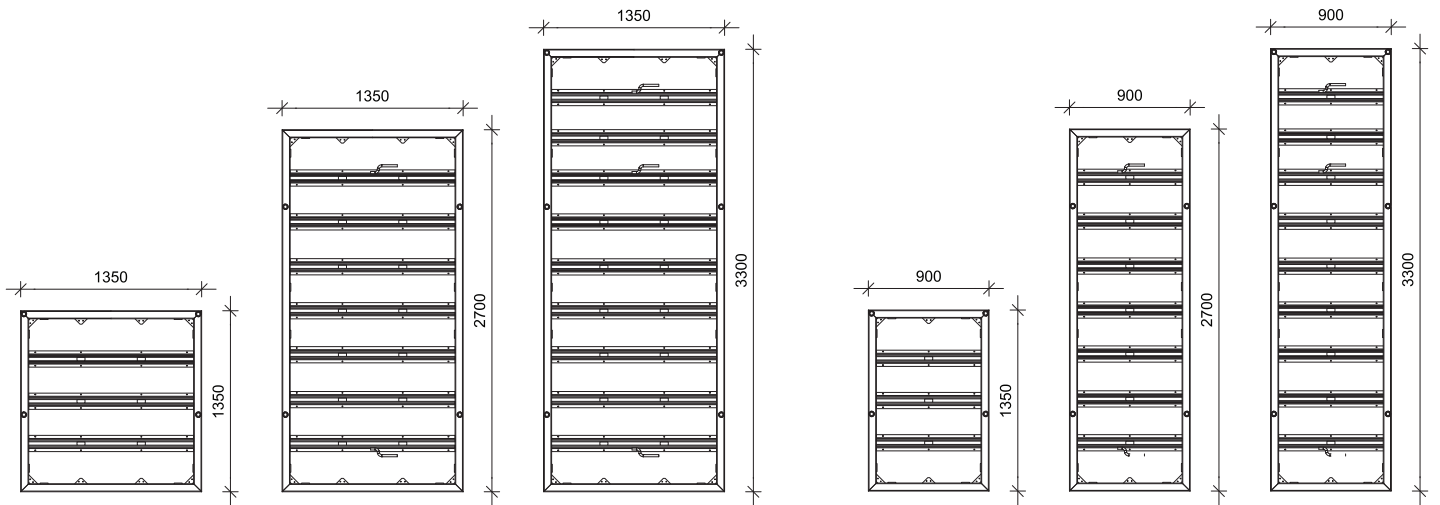

1350mm Family

900mm Family

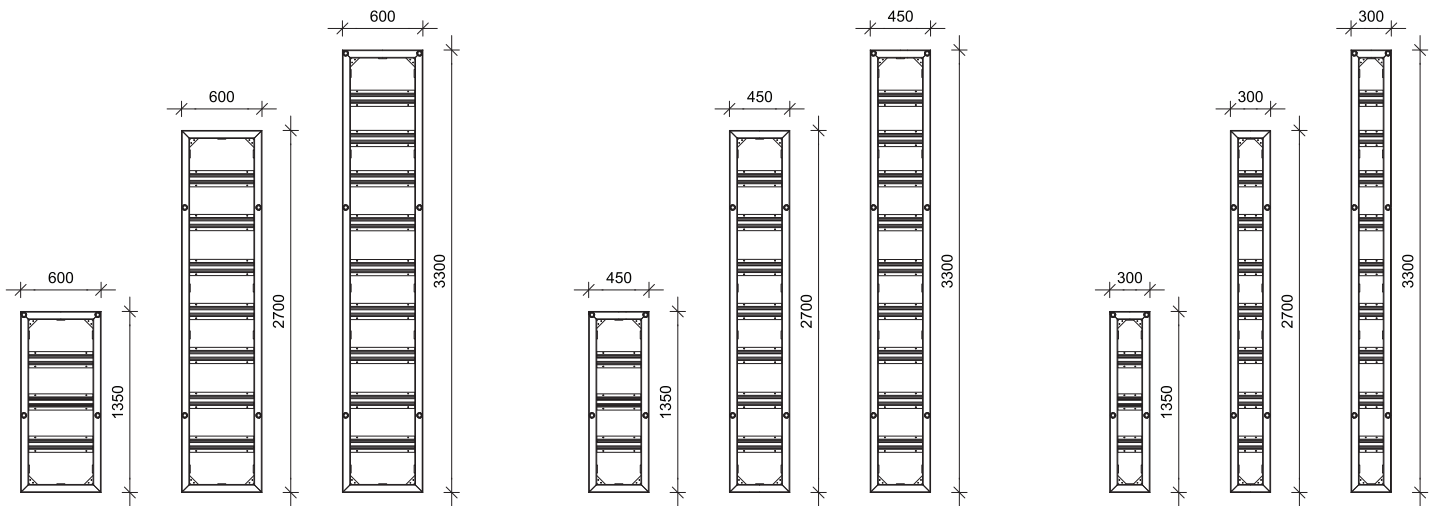

600mm Family

450mm Family

300mm Family

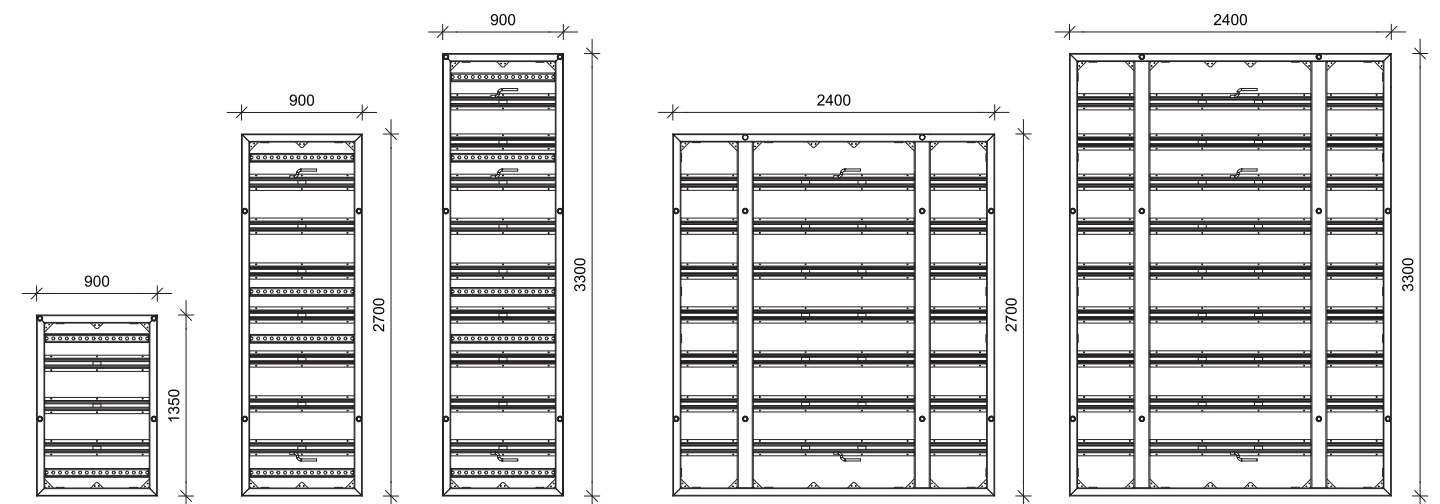

Universal Panels Family

Large Area Panels Family

S-Max Panels - Features and Details

Offering unparalleled flexibility on-site, S-Max panels come in 5 distinct widths and 3 different heights, enabling diverse forming possibilities. By embracing the S-Max exceptional features, you can leverage unparalleled adaptability, durability, and efficiency for your formwork needs.

Specially Designed Crane Hook Attachment

Safely and efficiently handle panels using the purpose-designed crane hook, which effortlessly attaches to the panel edge members, promoting secure and effective handling practices.

S-Max Border Profile

The panel's border profile consists of closed rolled hollow profiles. These profiles provide robust protection for the 18mm thickness quality plywood or phenolic coated, or plastic composite sheet that's seamlessly integrated into the panel. The composite sheet is riveted securely from the face side.

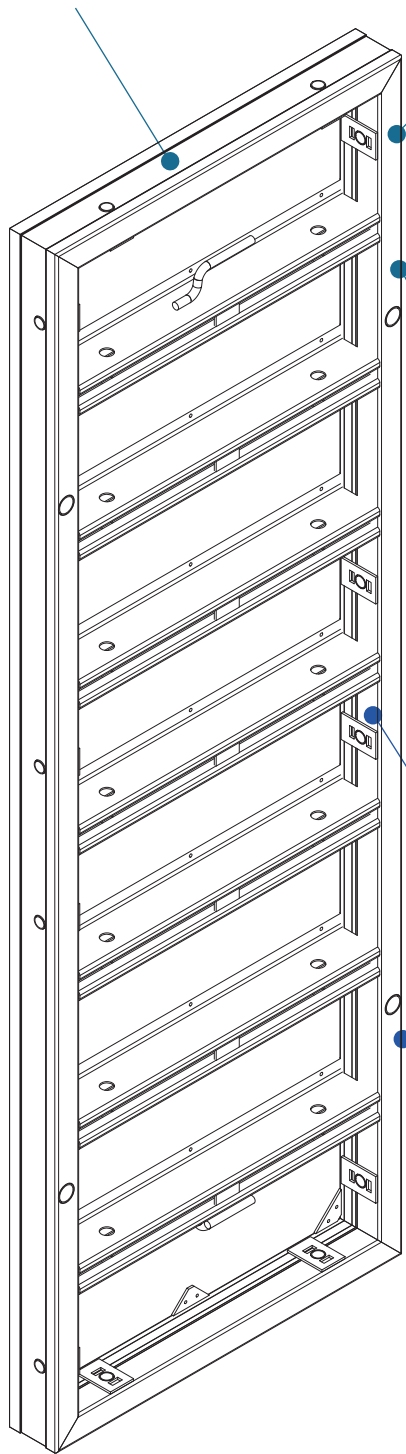

Galvanized Panel Frames

To ensure long-lasting usage without corrosion, each frame undergoes a hot-dipped galvanization procedure, significantly prolonging the lifespan of the panel. Additionally, powder coating or painted finishes are alternative choices available for the S-Max panels.

Efficient Connection Components

S-Max system is engineered for quick and adaptable assembly, thanks to an efficient arrangement of connecting parts. S-Max accepts many of the available accessories in the market ensuring seamless compatibility.

Tie System

Opt for 15mm or 20mm combination tie systems. With this feature, large panels can be used to handle lateral pressure up to 80kN/m² and can be adapted to meet a variety of requirements.

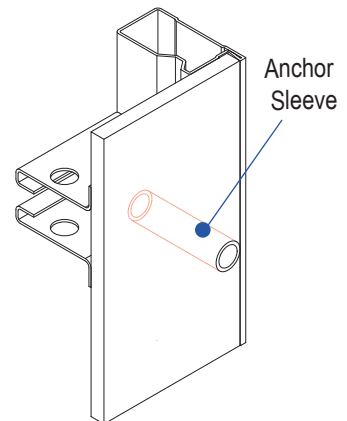
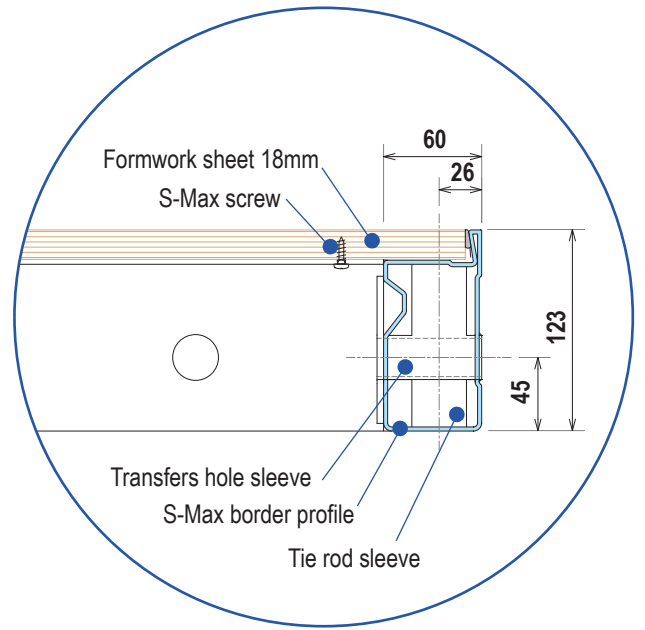

Panel connections



Simple panel connections

with the S-Max Clamp Device

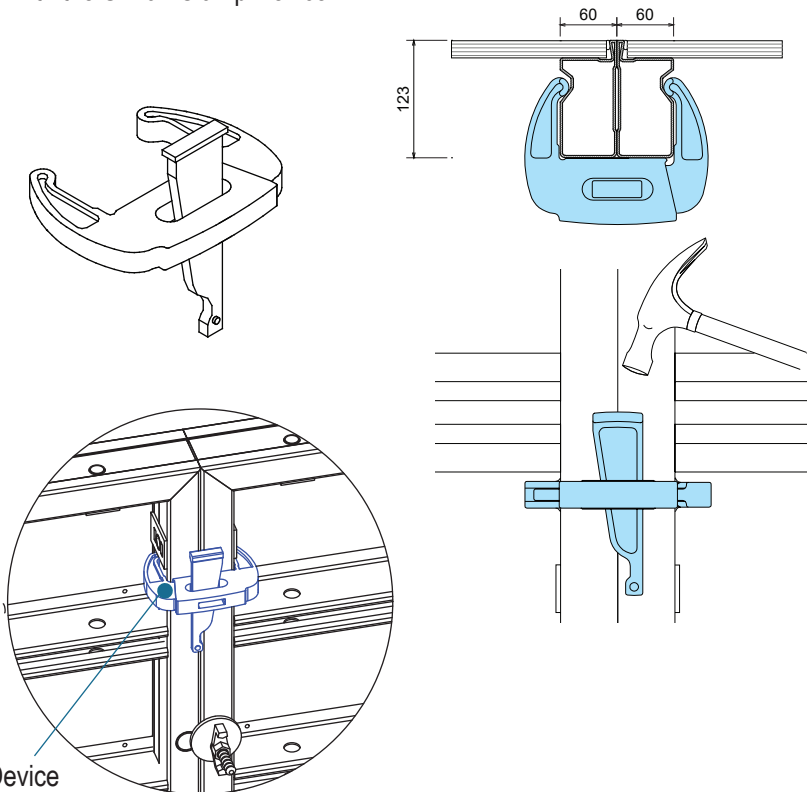

Closures: 0-20cm

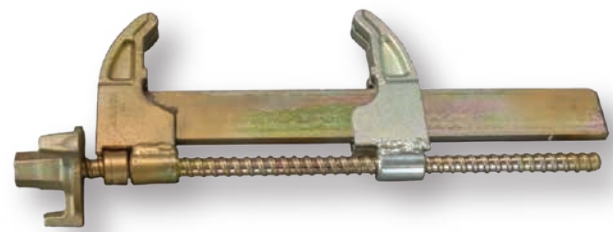
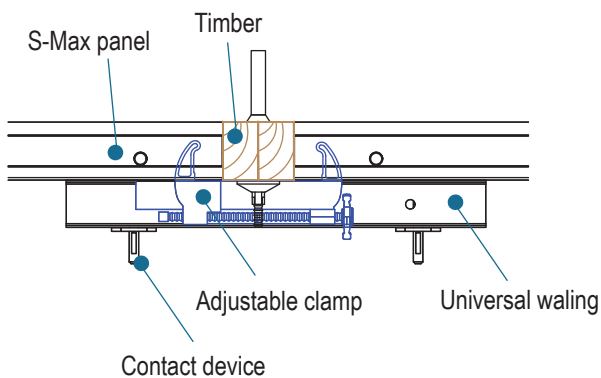

S-Max Adjustable Clamp

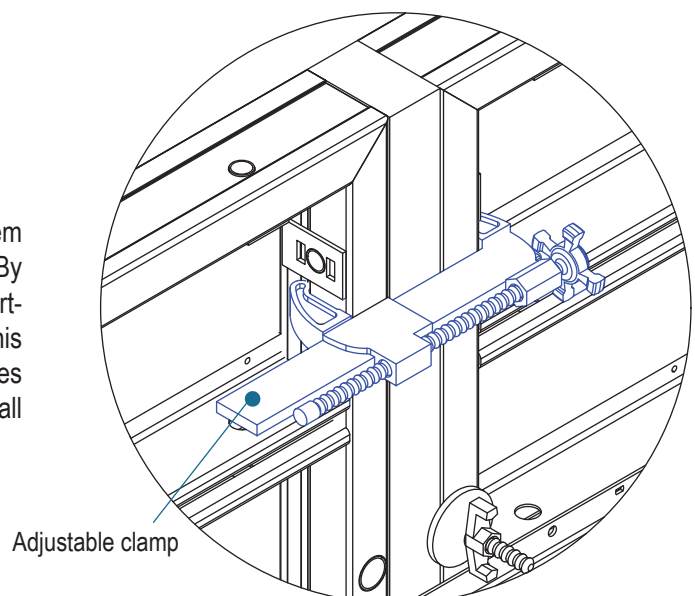

To provide a diverse range of wall lengths, the S-Max system offers an effective solution for constructing timber closures. By utilizing rectangular timber and plywood, S-Max enables the effortless formation of closures tailored to specific requirements. This versatile approach proves particularly effective for closures providing a reliable and efficient means of adapting to various wall dimensions with precision and ease.

System adaptability

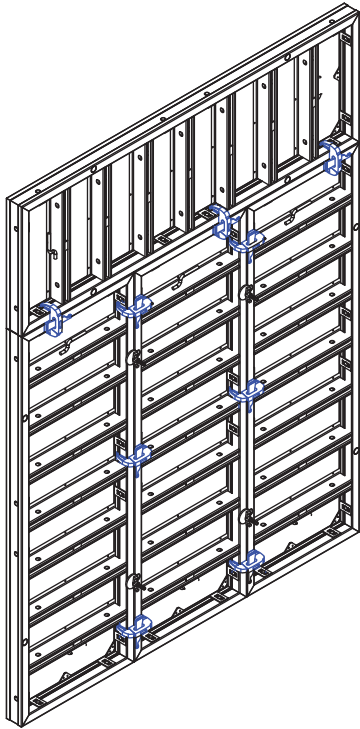

S-Max offers an exceptional panel grid that opens the door to an extensive array of combinations, available in both width and height variations. This ingenious system offers you the freedom to employ the panels in either an upright or sideways orientation, allowing you to cater to diverse construction needs.

At the heart of this system is the thoughtfully designed 15cm grid pattern, which serves as the cornerstone of its adaptability. This meticulously planned grid ensures that you achieve the utmost flexibility when it comes to adjusting the formwork to seamlessly align with the dimensions of your structure. Regardless of the intricacies and variations in your architectural design, the S-Max panel grid guarantees optimal interaction between formwork and structure, thereby enhancing efficiency and precision throughout the construction process.

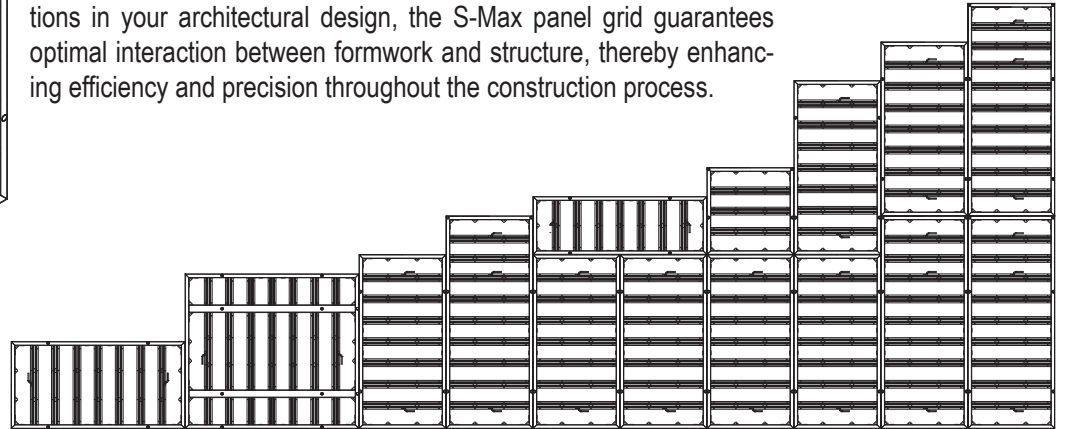

Incorporating extra universal walings enhances the structural integrity of multi-panel configurations, particularly when stacked to greater heights. This enhancement proves particularly advantageous when using cranes to maneuver substantial multi-panel assemblies with ease.

On closure, these supplementary universal walings also play a crucial role in redistributing loads. When the forms are being secured, the universal walings effectively align the multi-panel structures, facilitating the seamless transfer of form-tie forces to the S-Max panels.

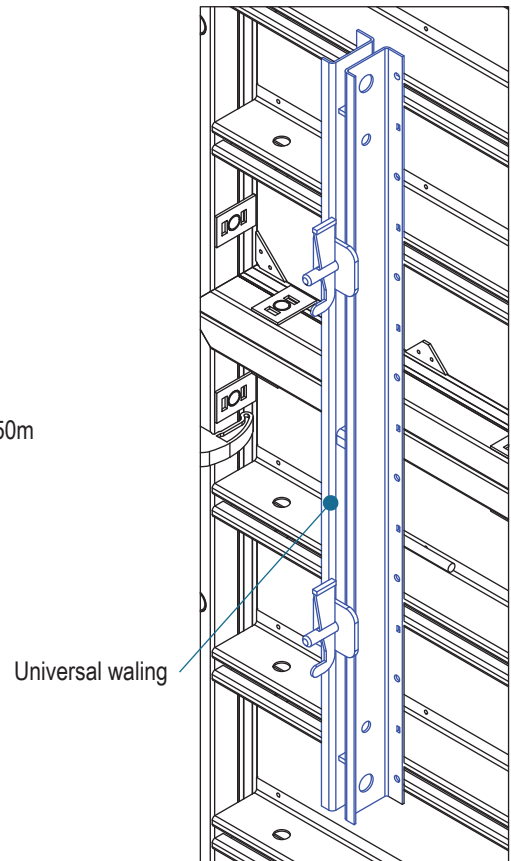
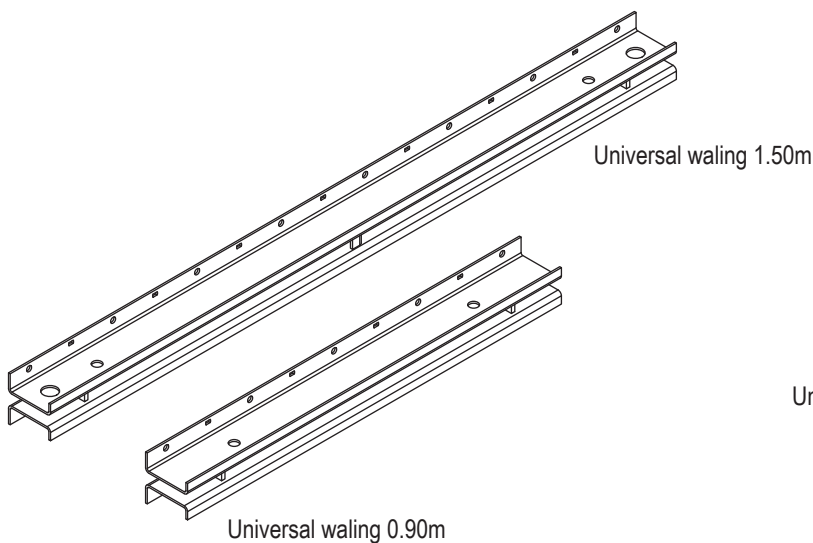

S-Max Plumbing Accessories

Double push-pull props play a pivotal role in maintaining the steadfast stability of panels when positioned in an upright orientation. These crucial structural elements not only contribute to upholding the panels' balance but also serve to simplify and enhance the process of aligning and adjusting the formwork for plumbing purposes.

By providing robust support and reinforcement, Push-Pull props prevent any unintended movement or swaying of the panels, ensuring that they remain securely fixed in their vertical configuration. This heightened stability is especially significant during construction projects where precision and reliability are paramount.

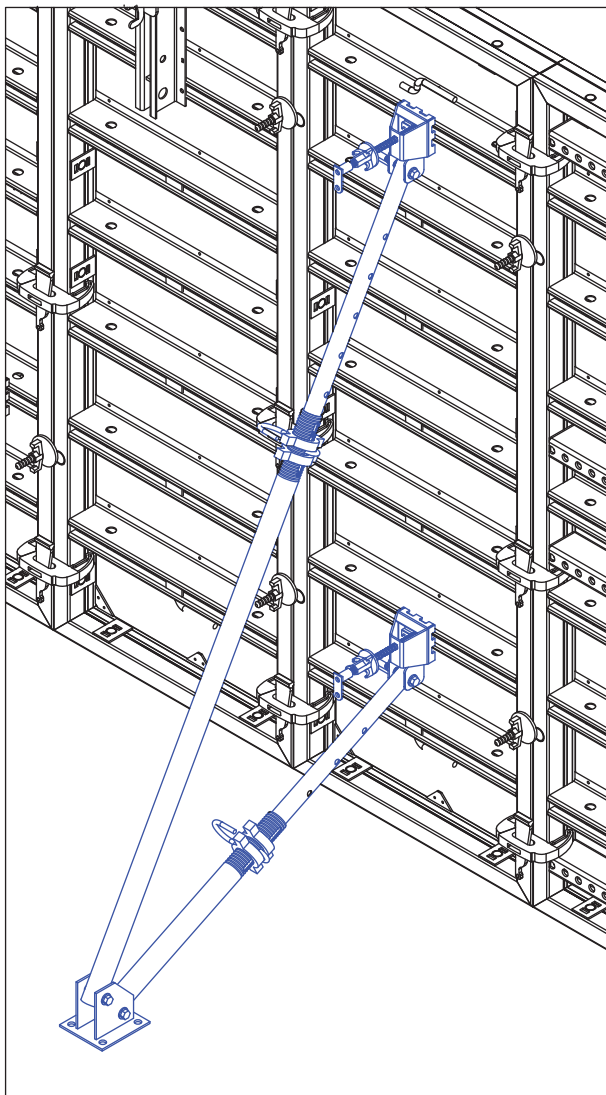
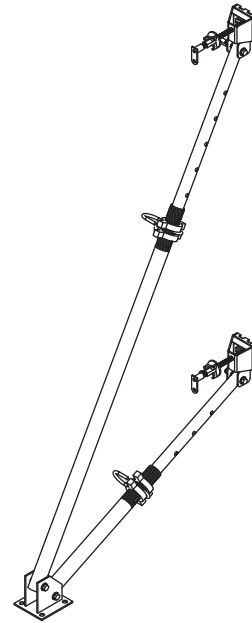

PP Prop Head

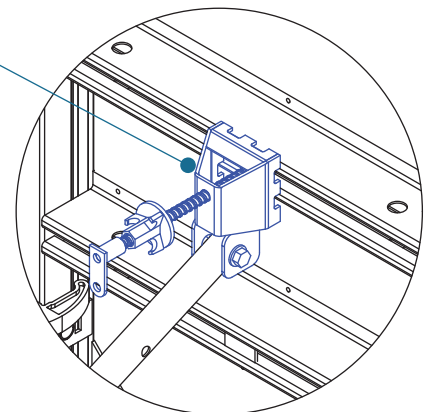

Double Push-Pull Prop Base

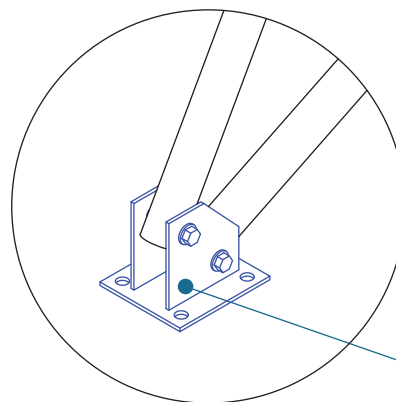

S-Max Access Bracket

Introducing the Access Bracket, a versatile solution for constructing pouring platforms. This innovative bracket enables the effortless manual assembly of these pouring platforms, simplifying the installation process. The Access Bracket is suitable for constructing a platform with a width of 90cm.

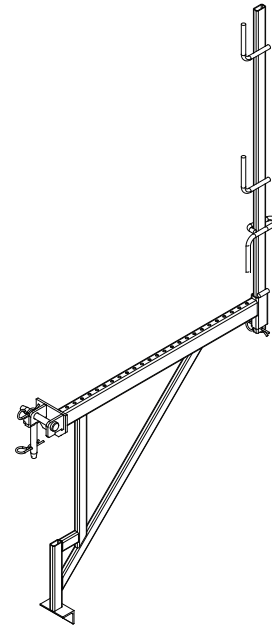

S-Max Formwork Tie System

15mm

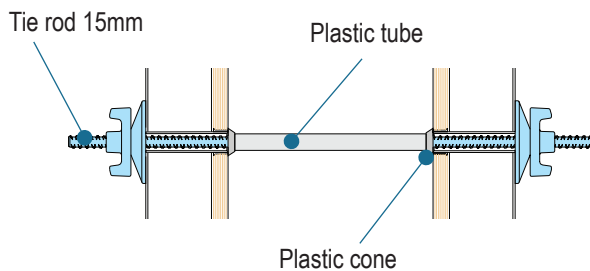

20mm

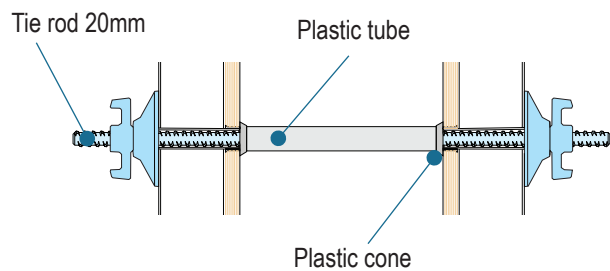

For high formwork pressures of up to 80kN/m^2 , use the form tie system 20mm

Moving by crane

Utilizing the lifting hook enables secure relocation of sizable gang-forms via crane. Once suspended, the lifting hook engages its automatic locking mechanism. The hook should be attached to suitable lifting ropes, ensuring a middle angle of no more than 60° . Each lifting hook is rated for a maximum load of 1000 Kg. For optimal positioning, place the lifting hook in proximity to the frame stiffenings.

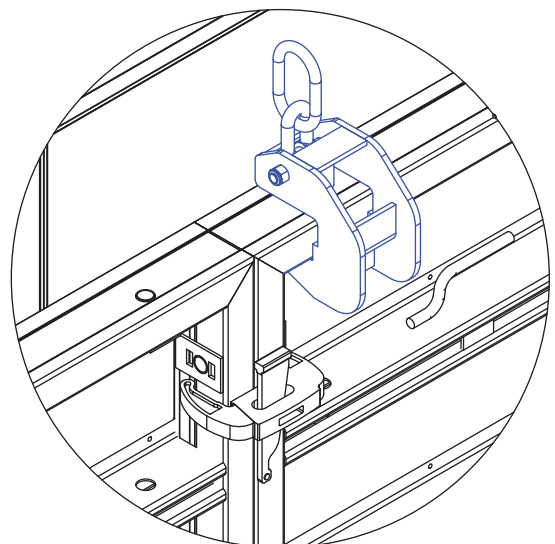
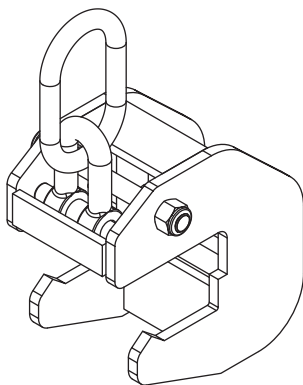

Method Statement - Construction Procedure of the S-Max Formwork

1. Panel Transport and Handling:

- Unload panels from the truck carefully to avoid damage.
- Use a certified lifting chain for lifting one panel at a time, ensuring safety and load stability.
- Large multi-panel configurations can be pre-assembled in a horizontal position on a level surface, utilizing S-Max connecting components for seamless integration.

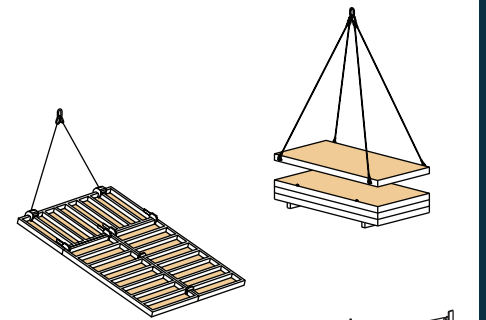

2. Formwork Assembly:

- Spray release agent on the formwork sheathing uniformly for easy demolding.
- Attach the crane suspension tackle to the S-Max lifting hook (Max. load capacity =1000kg per hook).
- Lift the formwork unit using the crane and position it accurately at the designated location.
- Clamp the push-pull props to the formwork unit securely while it is held by the crane.
- Fix the push-pull props to the ground to stabilize the formwork against wind forces and release the crane for other tasks. Plumb the formwork unit without crane assistance.
- Align and link panel assemblies systematically.
- Install pouring platforms and guardrails for safety.

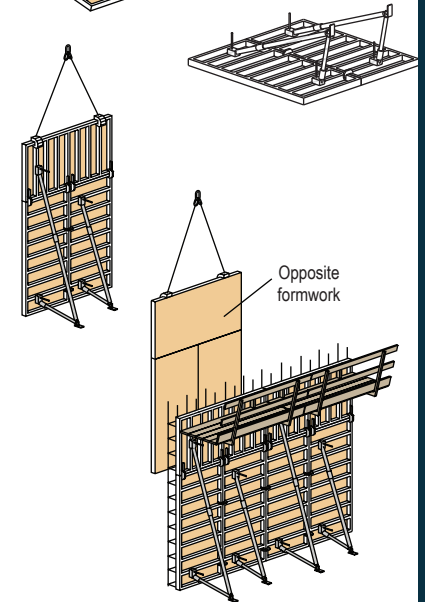

3. Erecting the Opposite Formwork Unit:

- After placing reinforcement, close the formwork.
- Apply release agent to the opposite formwork unit and relocate it using the crane to the required location.
- Fit form-ties before disconnecting from the crane.
- If the opposite formwork lacks push-pull props, do not disconnect the formwork from the crane until an adequate number of formwork ties have been installed to stabilize the entire formwork assembly.
- Install the remaining form-ties.

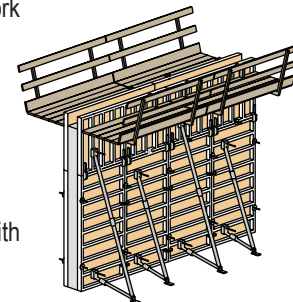

4. Pouring Concrete:

- Pour concrete within the maximum permissible rate of placing to ensure structural stability.
- Use vibrators moderately, coordinating their usage time and location carefully to comply with standards.
- Compaction of concrete by vibration must adhere to relevant standards.
- Immediately after pouring, clean the rear wall of the formwork with water.

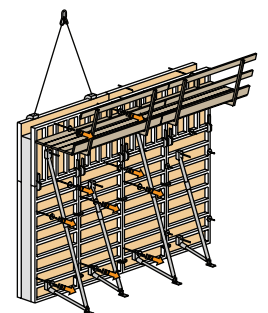

5. Striking and Moving Formwork to the Next Location:



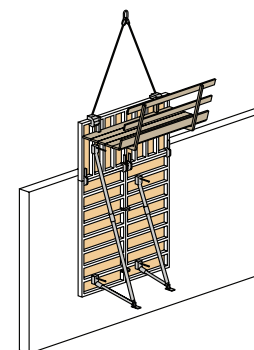

- Adhere to minimum striking times specified by the structural engineer.
- Remove loose items from the formwork and platforms.
- Attach the opposite formwork unit to the crane before removing form-ties and undoing panel clamps that connect panels.
- To expedite crane operations, pre-remove most form-ties, ensuring sufficient ties remain to prevent formwork instability.
- When stripping the formwork, avoid using the crane to break cohesion between concrete and formwork, as this could lead to a risk of crane overload. Instead, utilize appropriate tools such as timber wedges or a special pry-bar to detach the formwork from the concrete.
- Hoist the formwork unit and either store it temporarily or lift it to its next location.
- Clean residual concrete off the formwork sheathing for reuse.

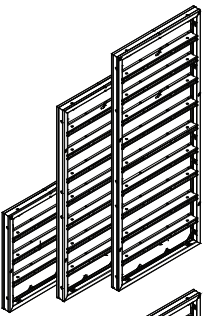
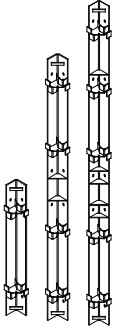
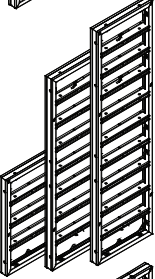
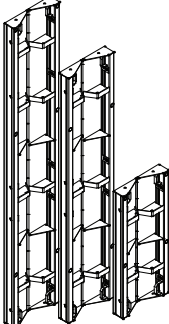
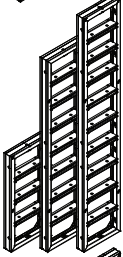
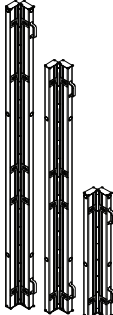
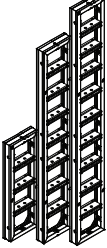
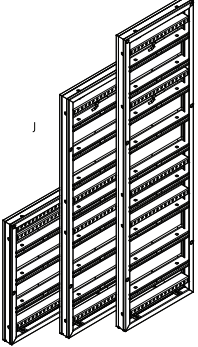
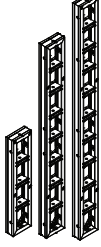
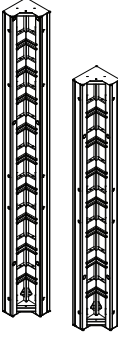
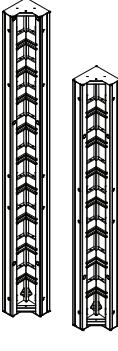
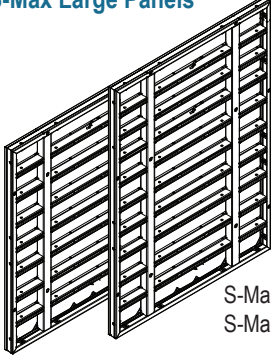

6. Lifting Formwork Unit with Push-Pull Props and Access Bracket:

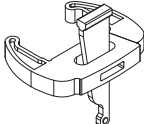
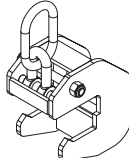
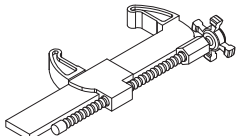
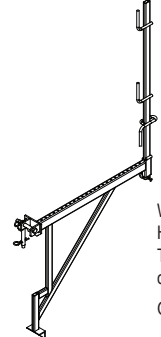
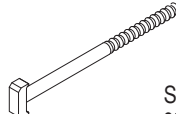
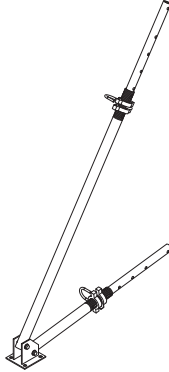
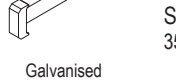
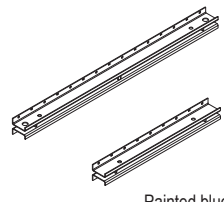
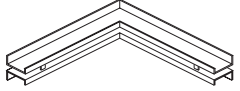
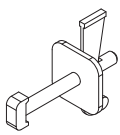
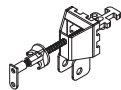
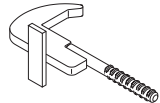
- Suspend the form (with push-pull props and access bracket attached) from the crane before undoing ground anchor points of the push-pull props, ensuring safety and stability during lifting operations.

S-Max Panels		Wt. (kg)	Code	S-Max Outside Corners		Wt. (kg)	Code
	S-Max Panel 3300 x 1350	211.43	FSCPHPLS3300135A		S-Max Outside Corner 3300	57.87	FSCPOCRSXXX0330A
	S-Max Panel 2700 x 1350	173.25	FSCPHPLS2700135A		S-Max Outside Corner 2700	46.51	FSCPOCRSXXX0270A
	S-Max Panel 1350 x 1350	92.99	FSCPHPLS1350135A		S-Max Outside Corner 1350	23.06	FSCPOCRSXXX0135A
	S-Max Panel 3300 x 900	157.48	FSCPHPLS3300090A		Hinged Inside Corners 3300	139.71	FSCPHICS0580330A
	S-Max Panel 2700 x 900	128.98	FSCPHPLS2700090A		Hinged Inside Corners 2700	114.51	FSCPHICS0580270A
	S-Max Panel 1350 x 900	68.75	FSCPHPLS1350090A		Hinged Inside Corners 1350	61.77	FSCPHICS0580135A
	S-Max Panel 3300 x 600	109.21	FSCPHPLS3300060A		Hinged Outside Corners 3300	78.69	FSCPHOCSXXX0330A
	S-Max Panel 2700 x 600	89.25	FSCPHPLS2700060A		Hinged Outside Corners 2700	64.22	FSCPHOCSXXX0270A
	S-Max Panel 1350 x 600	46.96	FSCPHPLS1350060A		Hinged Outside Corners 1350	33.61	FSCPHOCSXXX0135A
	S-Max Panel 3300 x 450	92.02	FSCPHPLS3300045A		Universal Panel 3300 x 900	197.07	FSCPUPLS1350330A
	S-Max Panel 2700 x 450	75.10	FSCPHPLS2700045A		Universal Panel 2700 x 900	160.66	FSCPUPLS0900330A
	S-Max Panel 1350 x 450	39.38	FSCPHPLS1350045A		Universal Panel 1350 x 900	84.58	FSCPUPLS0750330A
	S-Max Panel 3300 x 300	74.80	FSCPHPLS3300030A		S-Max Inside Corner 3300	113.07	FSCPICAS0600330A
	S-Max Panel 2700 x 300	61.16	FSCPHPLS2700030A		S-Max Inside Corner 2700	92.44	FSCPICAS0600270A
	S-Max Panel 1350 x 300	31.92	FSCPHPLS1350030A		S-Max Inside Corner 1350	48.65	FSCPICAS0600135A
Galvanised and powder-coated Overall depth: 12.3cm				S-Max Large Panels			
							
Powder-coated, blue Edge-to-corner dimension: 30cm				S-Max Panel 3300 x 2400 415.07 FSCPLPLS2400330A			
				S-Max Panel 2700 x 2400 340.81 FSCPLPLS2400270A			

	Wt. (kg)	Code		Wt. (kg)	Code
S-Max Clamp Device  Galvanised	3.50	FTRGCDVPFHDXXXA	S-Max Lifting Hook  Max. load: 1000 kg per lifting hook Galvanised	11.00	FCFPLFBSXXXXXXAA
S-Max Adjustable Clamp  Galvanised	5.75	FTRGCADPFHDXXXA	S-Max Access Bracket  Width: 103cm Height: 185cm The Access Bracket is suitable for constructing a platform with a width of 90cm. Galvanised	13.50	FCFEWBRSTXXXXXXAA
S-Max T-Bolts S-Max T-Bolt 26cm  Galvanised	0.65	FTRGGCSPF1016XXA	Double Push-Pull Prop  Double Push-Pull Prop 350 31.00 FCFEWBRSTXXXXXXAA Double Push-Pull Prop 600 51.00 FCFGPST540XXXXXB		
S-Max T-Bolt 35cm  Galvanised	0.75	FTRGGCSPF1025XXA			
S-Max Universal Walings  Painted blue	S-Max Uni. Walings 0.90m 10.60 FCFPGPLS090XXXXA S-Max Uni. Walings 1.50m 16.80 FCFPGPLS150XXXXA				
S-Max Corner Waling  Painted blue	13.00	XXX			
S-Max Contact Device  Galvanised	1.45	XXX	PP Prop Head 	3.00	XXX
S-Max End Tie  Galvanised	1.60	XXX			
Hexagon nut 15  Galvanised	0.23	XXX			
S-Max Plate 15  Galvanised	0.80	XXX			
Anchor plate 15  Galvanised	1.10	XXX			

Phone:

+971 4 886 2855

Email Us:

sales@scaffco.com

Address:

P.O. BOX 18234 Jebel Ali Dubai – UAE

Phone:

+971 2 550 0688

Email Us:

sales@scaffco.com

Address:

PO. BOX 41851- Abu Dhabi – UAE